

Quantum criticality,  
the AdS/CFT correspondence,  
and the  
cuprate superconductors

Talk online: [sachdev.physics.harvard.edu](http://sachdev.physics.harvard.edu)





Max Metlitski, Harvard

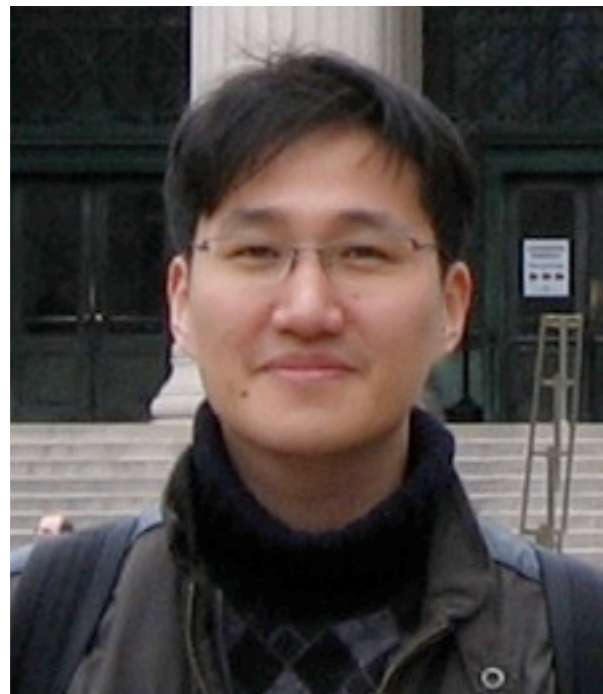

Eun Gook Moon, Harvard

Frederik Denef, Harvard  
Sean Hartnoll, Harvard  
Christopher Herzog, Princeton  
Pavel Kovtun, Victoria  
Dam Son, Washington



# Outline

## 1. The superfluid-insulator transition

*Quantum criticality and  
the AdS/CFT correspondence*

## 2. Graphene

*'Topological' Fermi surface transition*

## 3. The cuprate superconductors

*Fluctuating spin density waves, and  
pairing by "topological" gauge fluctuations*

# Outline

## 1. The superfluid-insulator transition

*Quantum criticality and  
the AdS/CFT correspondence*

## 2. Graphene

*'Topological' Fermi surface transition*

## 3. The cuprate superconductors

*Fluctuating spin density waves, and  
pairing by "topological" gauge fluctuations*

# Superfluid-insulator transition

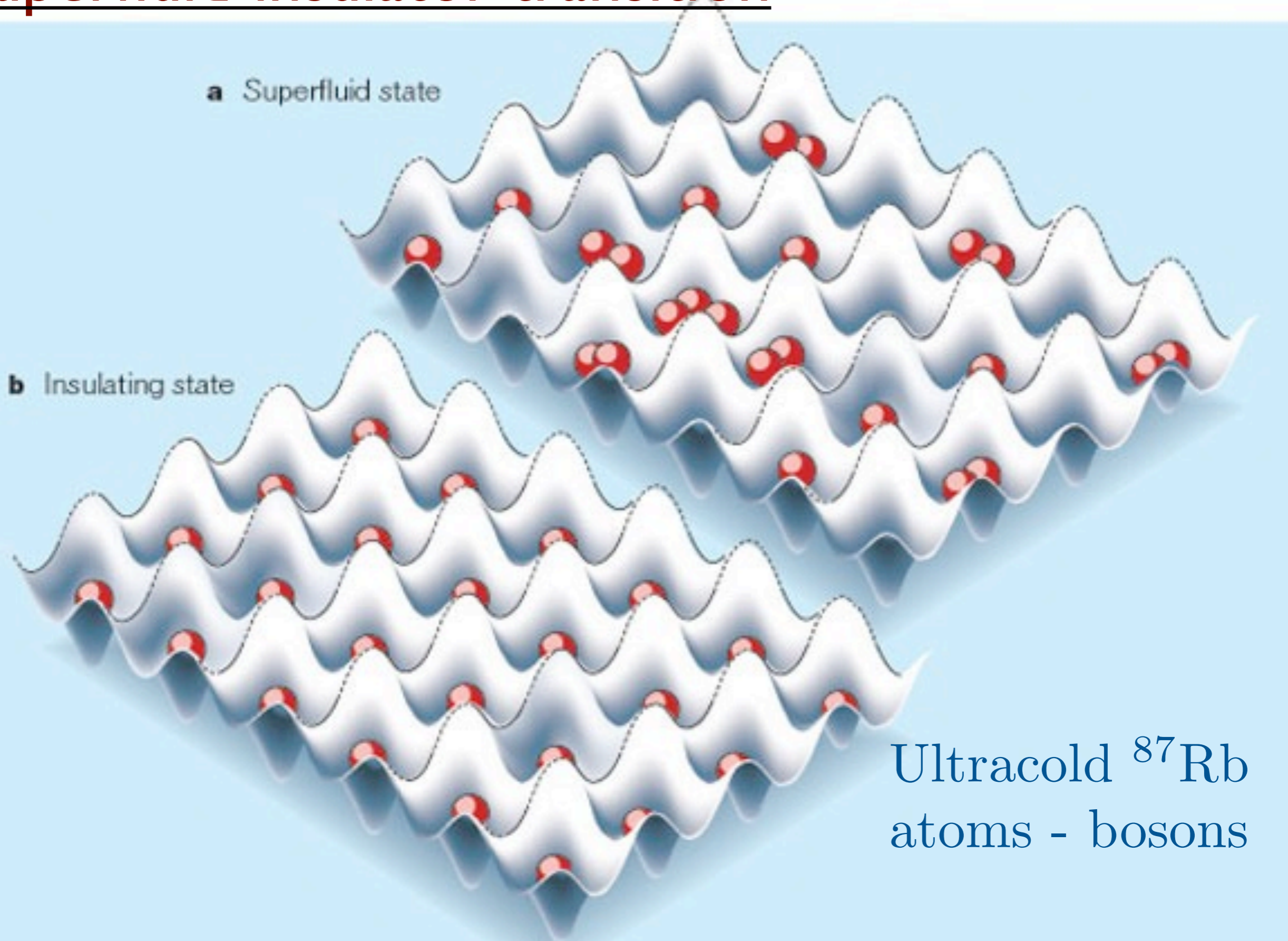

Ultracold  $^{87}\text{Rb}$   
atoms - bosons

M. Greiner, O. Mandel, T. Esslinger, T. W. Hänsch, and I. Bloch, *Nature* **415**, 39 (2002).



Insulator (the vacuum) at large  $U$

Excitations:

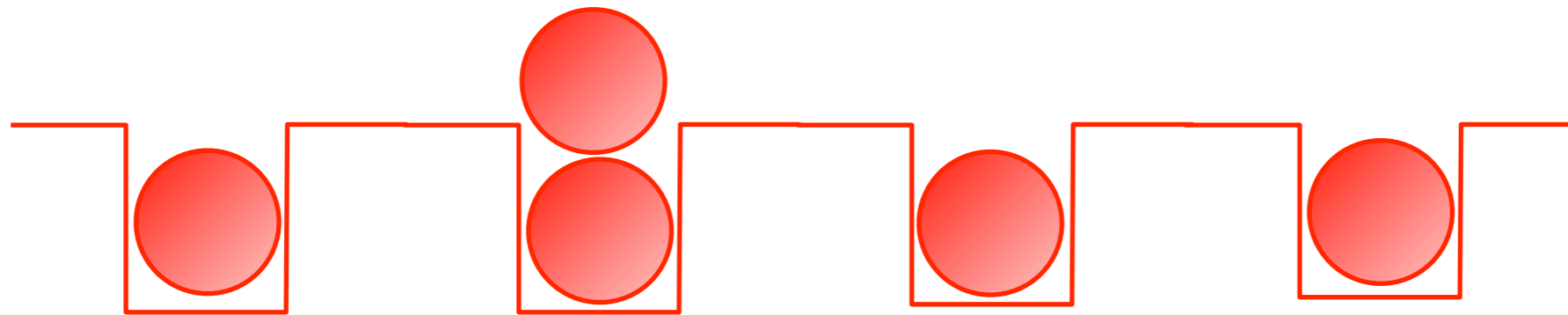

Particles  $\sim \psi^\dagger$

Excitations:

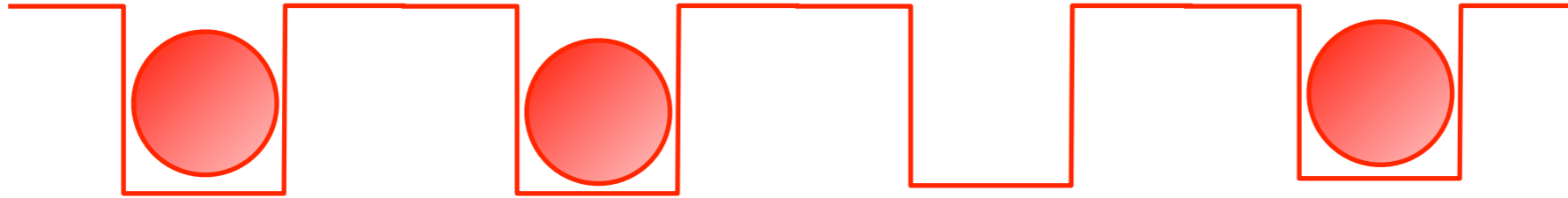

Holes  $\sim \psi$

## Excitations of the insulator:

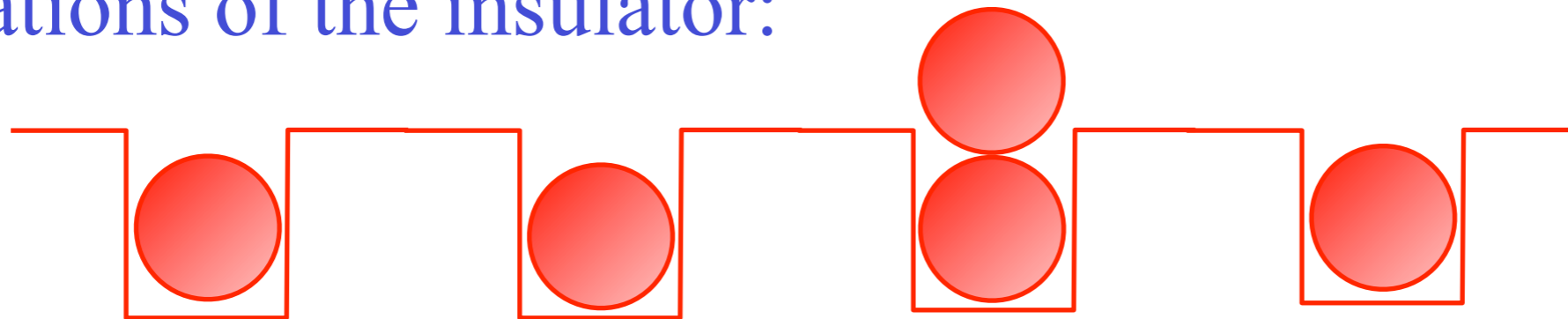

Particles  $\sim \psi^\dagger$



Holes  $\sim \psi$

Density of particles = density of holes  $\Rightarrow$

“relativistic” field theory for  $\psi$ :

$$\mathcal{S} = \int d^2r d\tau \left[ |\partial_\tau \psi|^2 + v^2 |\vec{\nabla} \psi|^2 + (g - g_c) |\psi|^2 + \frac{u}{2} |\psi|^4 \right]$$

Insulator  $\Leftrightarrow \langle \psi \rangle = 0$

Superfluid  $\Leftrightarrow \langle \psi \rangle \neq 0$

$$\mathcal{S} = \int d^2r d\tau \left[ |\partial_\tau \psi|^2 + v^2 |\vec{\nabla} \psi|^2 + (g - g_c) |\psi|^2 + \frac{u}{2} |\psi|^4 \right]$$

$$\langle \psi \rangle \neq 0$$

Superfluid

$$\langle \psi \rangle = 0$$

Insulator

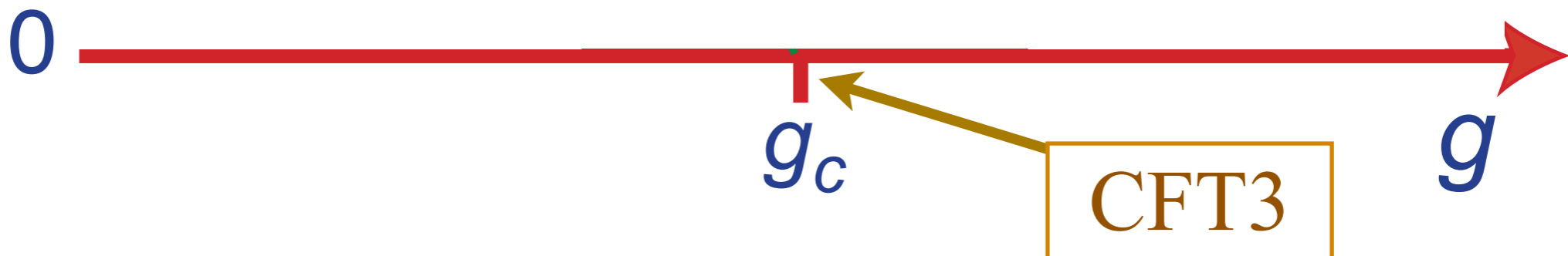

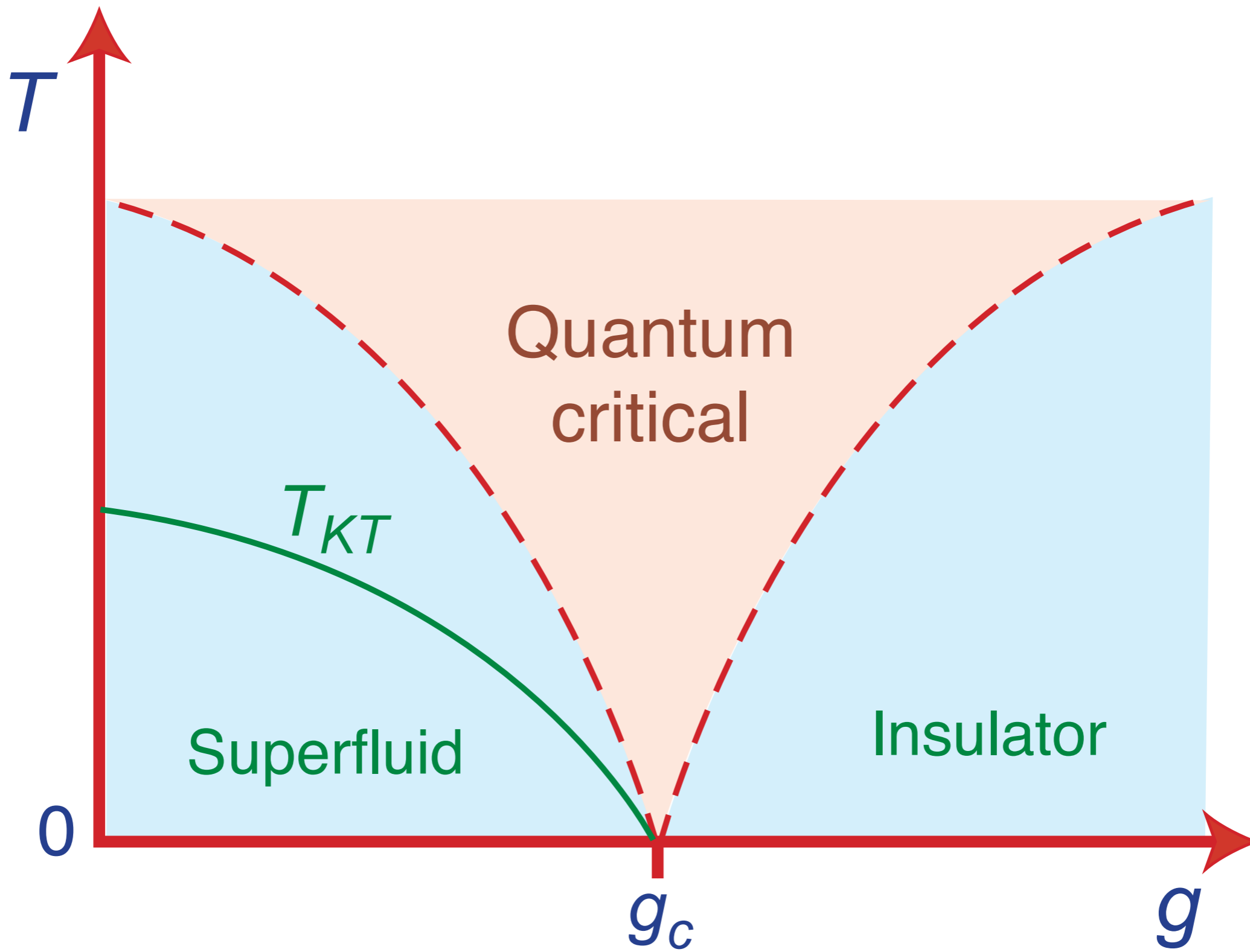

Classical vortices and wave oscillations of the condensate

Dilute Boltzmann/Landau gas of particle and holes

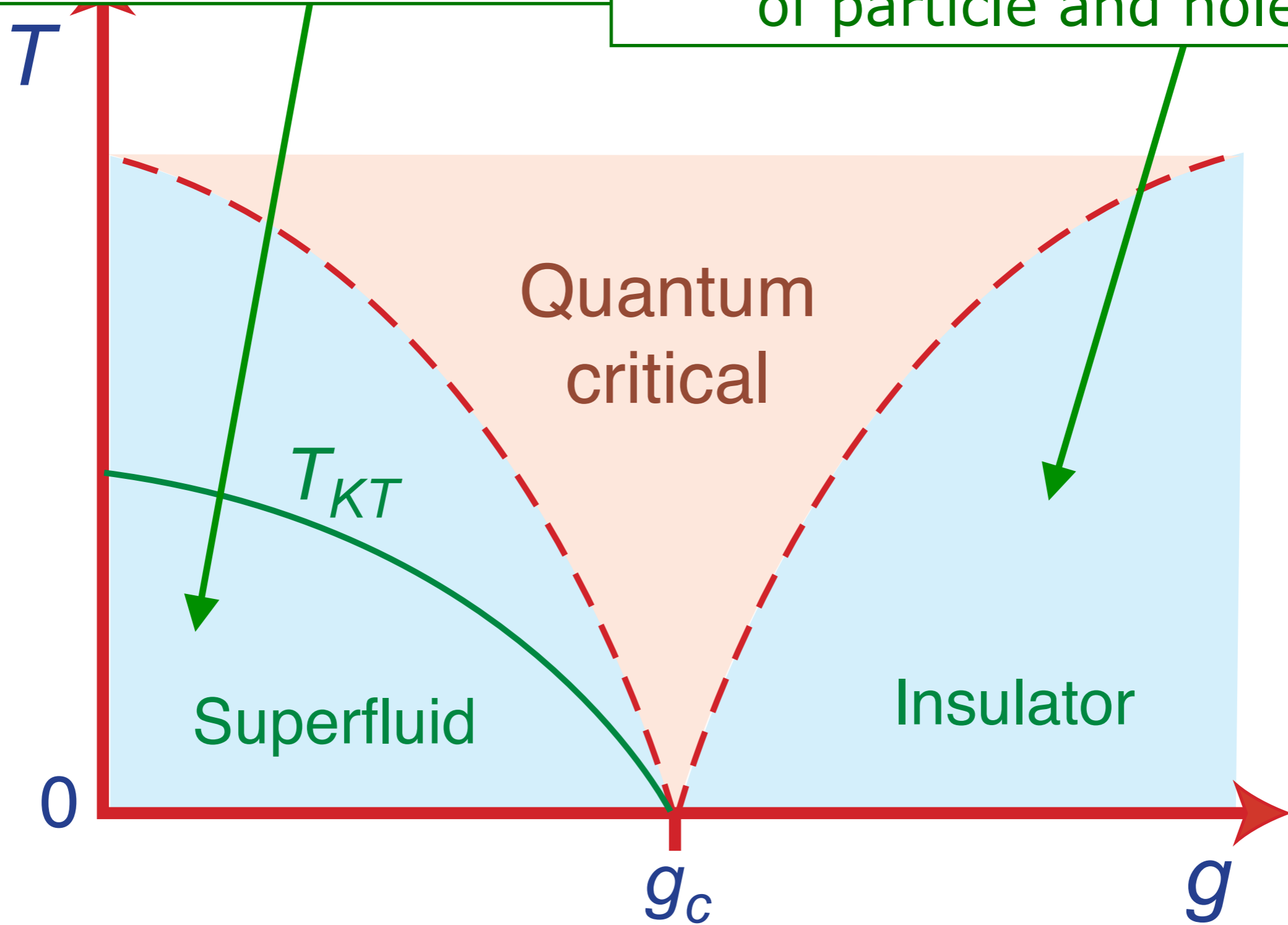

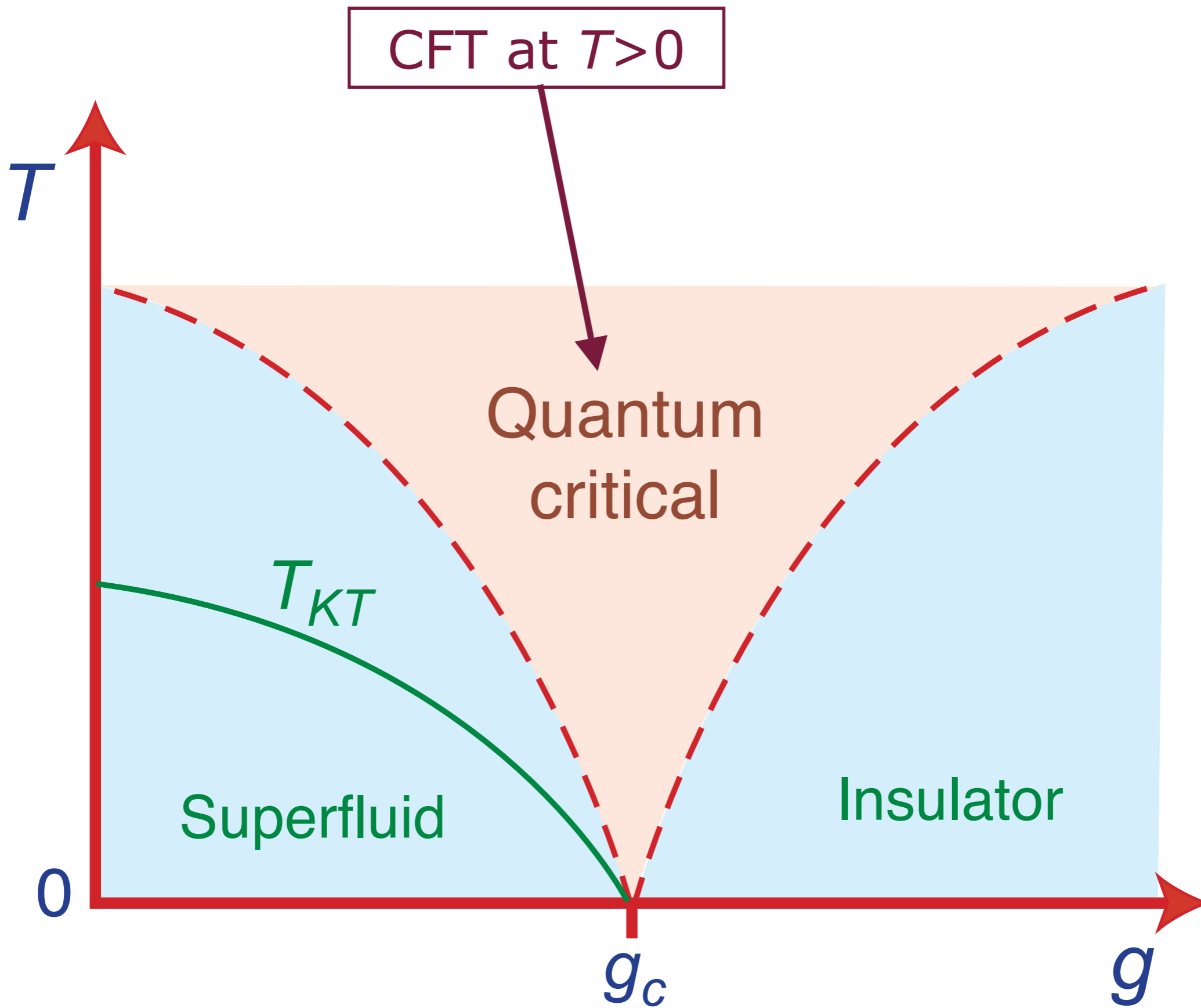

# Resistivity of Bi films

## Conductivity $\sigma$

$$\sigma_{\text{Superconductor}}(T \rightarrow 0) = \infty$$

$$\sigma_{\text{Insulator}}(T \rightarrow 0) = 0$$

$$\sigma_{\text{Quantum critical point}}(T \rightarrow 0) \approx \frac{4e^2}{h}$$

D. B. Haviland, Y. Liu, and A. M. Goldman,  
*Phys. Rev. Lett.* **62**, 2180 (1989)

M. P. A. Fisher, *Phys. Rev. Lett.* **65**, 923 (1990)

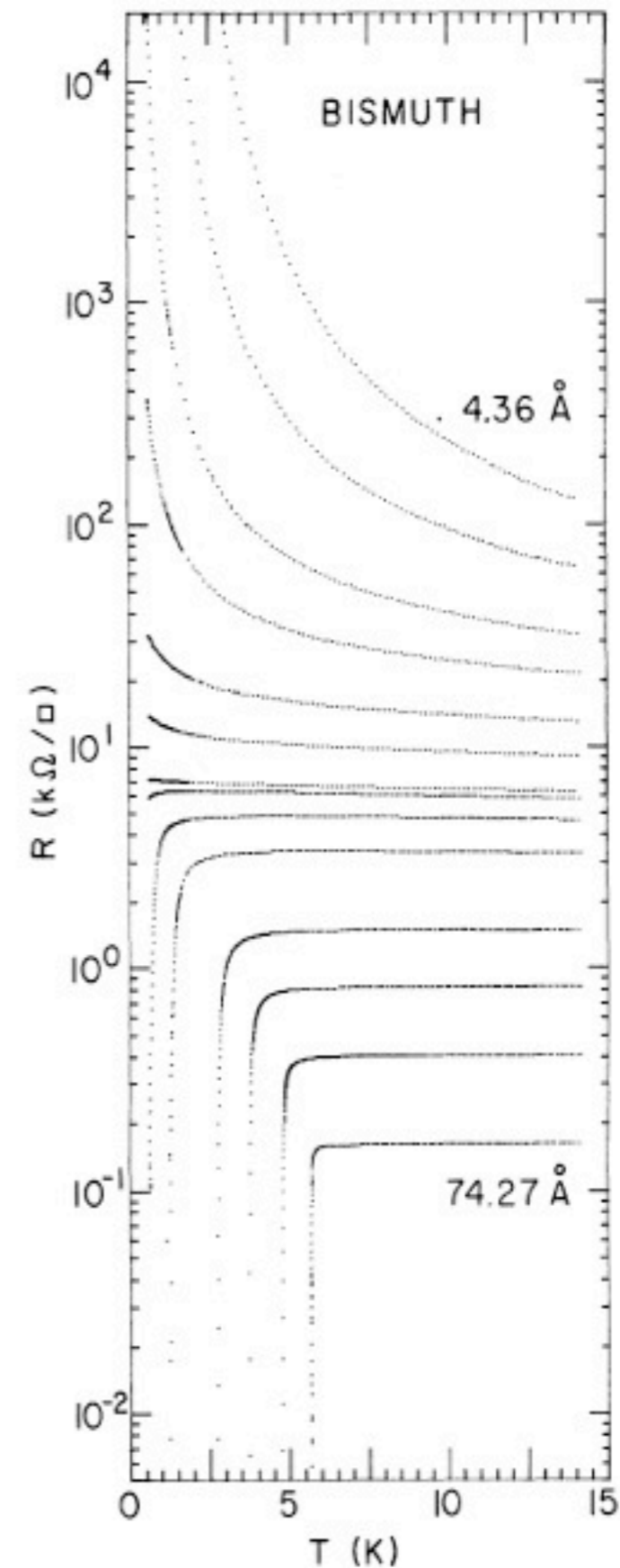

FIG. 1. Evolution of the temperature dependence of the sheet resistance  $R(T)$  with thickness for a Bi film deposited onto Ge. Fewer than half of the traces actually acquired are shown. Film thicknesses shown range from 4.36 to 74.27 Å.

# Quantum critical transport

Quantum “*perfect fluid*”  
with shortest possible  
relaxation time,  $\tau_R$

$$\tau_R \gtrsim \frac{\hbar}{k_B T}$$

# Quantum critical transport

Transport co-efficients not determined  
by collision rate, but by  
universal constants of nature

## Electrical conductivity

$$\sigma = \frac{4e^2}{h} \times [\text{Universal constant } \mathcal{O}(1) ]$$

K. Damle and S. Sachdev, *Phys. Rev. B* **56**, 8714 (1997).

# Quantum critical transport

Transport co-efficients not determined  
by collision rate, but by  
universal constants of nature

## Momentum transport

$$\frac{\eta}{s} \equiv \frac{\text{viscosity}}{\text{entropy density}}$$
$$= \frac{\hbar}{k_B} \times [\text{Universal constant } \mathcal{O}(1)]$$

P. Kovtun, D. T. Son, and A. Starinets, *Phys. Rev. Lett.* **94**, 11601 (2005)

$$\sigma = \frac{4e^2}{h} \Sigma$$

$\Sigma$ , a universal number.

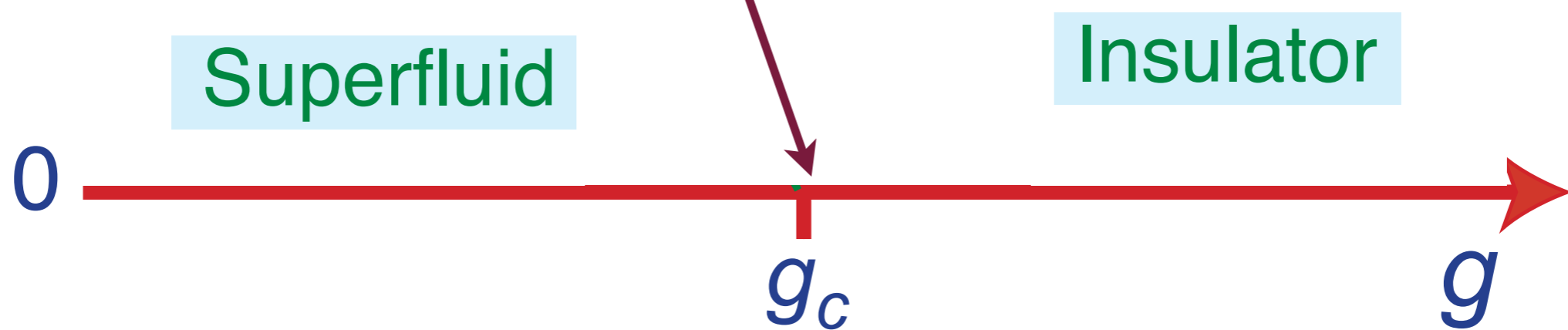

$$\sigma = \frac{4e^2}{h} \Sigma \left( \frac{\hbar\omega}{k_B T} \right)$$

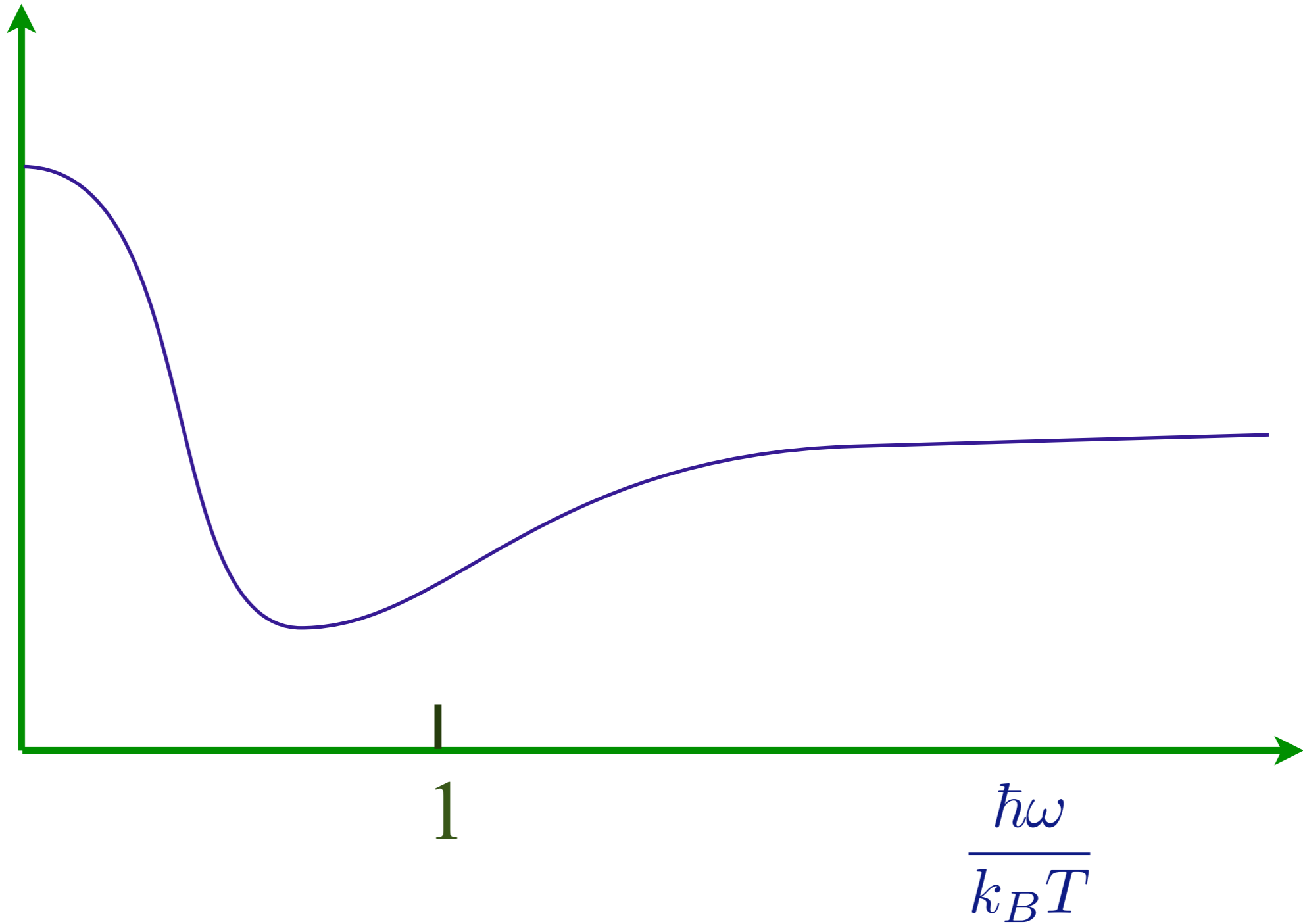

K. Damle and S. Sachdev, 1997

$$\sigma = \frac{4e^2}{h} \Sigma \left( \frac{\hbar\omega}{k_B T} \right)$$

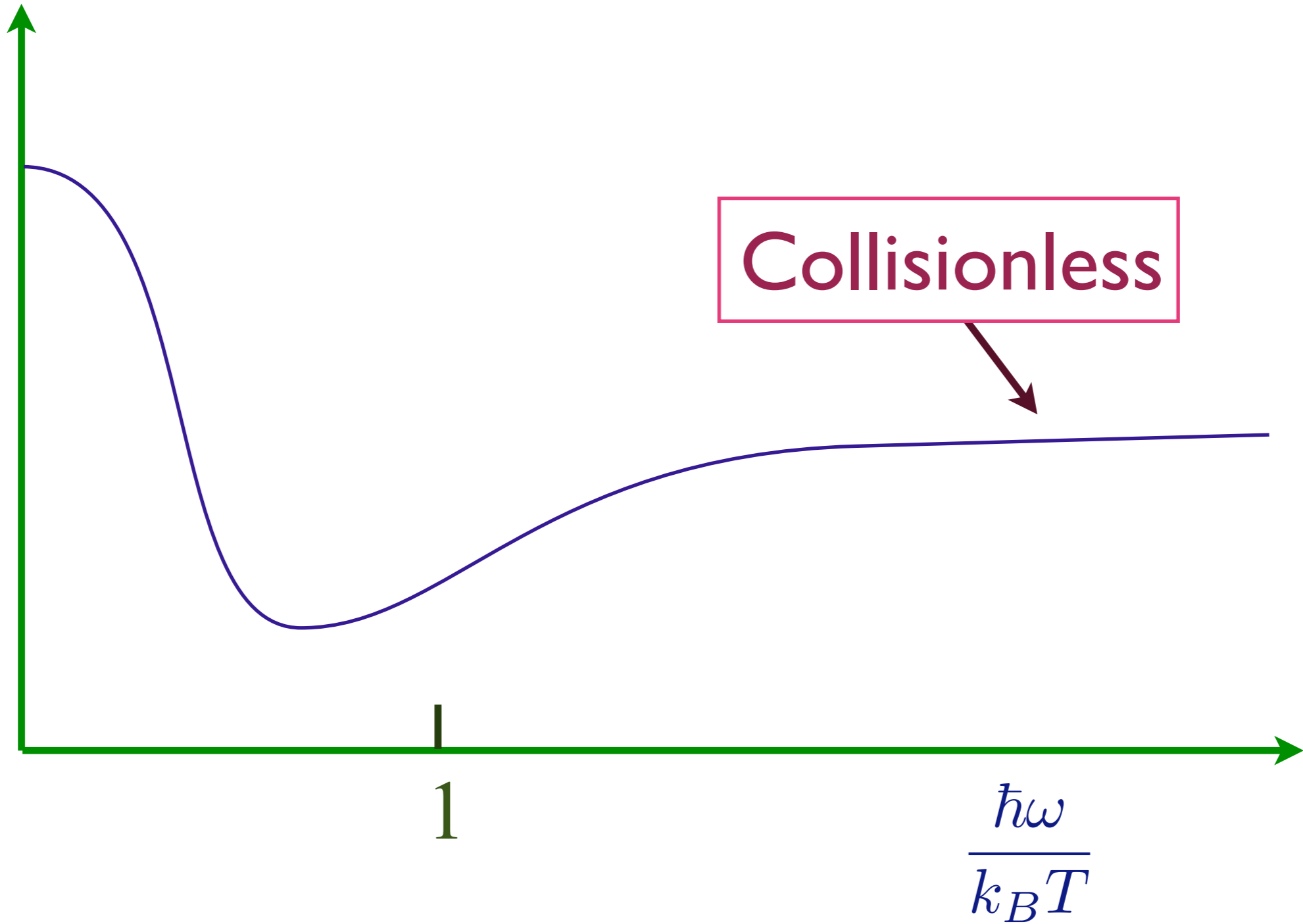

K. Damle and S. Sachdev, 1997

$$\sigma = \frac{4e^2}{h} \Sigma \left( \frac{\hbar\omega}{k_B T} \right)$$

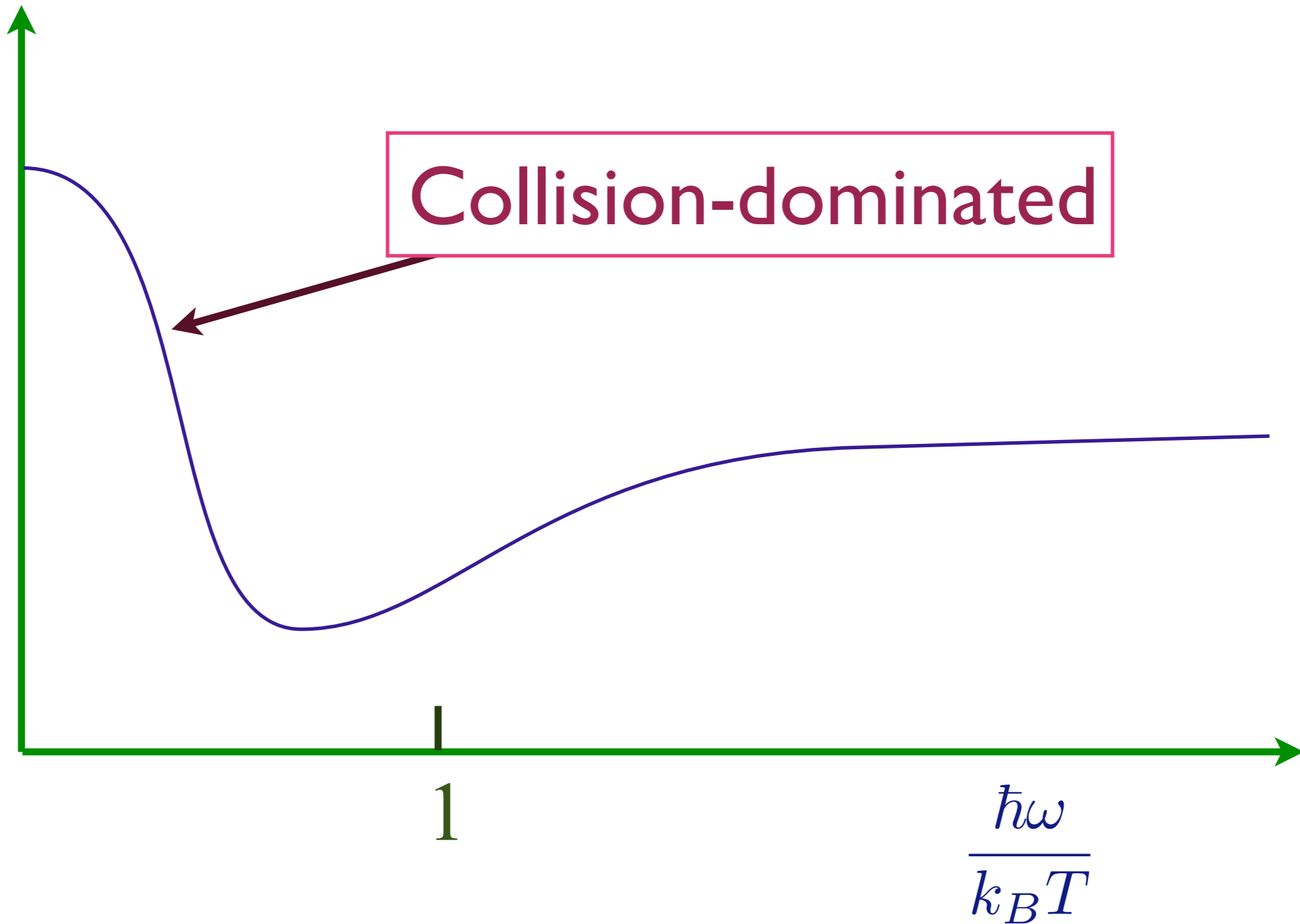

K. Damle and S. Sachdev, 1997

Using the boson quasiparticle excitations of the insulator  $\sim \psi$

$$\mathcal{S} = \int d^3x \left[ |\partial_\mu \psi|^2 + s|\psi|^2 + \frac{u}{2}|\psi|^4 \right]$$

Using the boson quasiparticle excitations of the insulator  $\sim \psi$

$$\mathcal{S} = \int d^3x \left[ |\partial_\mu \psi|^2 + s|\psi|^2 + \frac{u}{2}|\psi|^4 \right]$$

is dual to

Using the vortex quasiparticle excitations of the superfluid  $\sim \varphi$

$$\mathcal{S}_{\text{dual}} = \int d^3x \left[ |(\partial_\mu - iA_\mu)\varphi|^2 + \tilde{s}|\varphi|^2 + \frac{\tilde{u}}{2}|\varphi|^4 + \frac{1}{2e^2}(\epsilon_{\mu\nu\lambda}\partial_\nu A_\lambda)^2 \right]$$

- Now add Dirac fermions, generalize the gauge group to  $SU(N)$ , and allow maximal supersymmetry in  $2+1$  dimensions.

- Now add Dirac fermions, generalize the gauge group to  $SU(N)$ , and allow maximal supersymmetry in  $2+1$  dimensions.
- Yields a model whose transport properties can be computed exactly in the large  $N$  limit via the AdS/CFT correspondence.

- Now add Dirac fermions, generalize the gauge group to  $SU(N)$ , and allow maximal supersymmetry in  $2+1$  dimensions.
- Yields a model whose transport properties can be computed exactly in the large  $N$  limit via the AdS/CFT correspondence.

- Most importantly, the large  $N$  limit exhibits hydrodynamic behavior, and the thermal equilibration time remains finite as  $N \rightarrow \infty$ : this is a first for any solvable many body theory.

- Now add Dirac fermions, generalize the gauge group to  $SU(N)$ , and allow maximal supersymmetry in  $2+1$  dimensions.
- Yields a model whose transport properties can be computed exactly in the large  $N$  limit via the AdS/CFT correspondence.
- Most importantly, the large  $N$  limit exhibits hydrodynamic behavior, and the thermal equilibration time remains finite as  $N \rightarrow \infty$ : this is a first for any solvable many body theory.
- Critical conductivity  $\Sigma = \sqrt{2}N^{3/2}/3$  (“self-dual” value).

- For boson-vortex system, self-dual value is  $\Sigma = 1$ , closed to the observed values. Self-dual values are obtained for all models with simple gravity duals, analogous to  $\eta/s = \hbar/(4\pi k_B)$ .

# Collisionless to hydrodynamic crossover of SYM3

$$\text{Im}\chi(k, \omega)/k^2$$

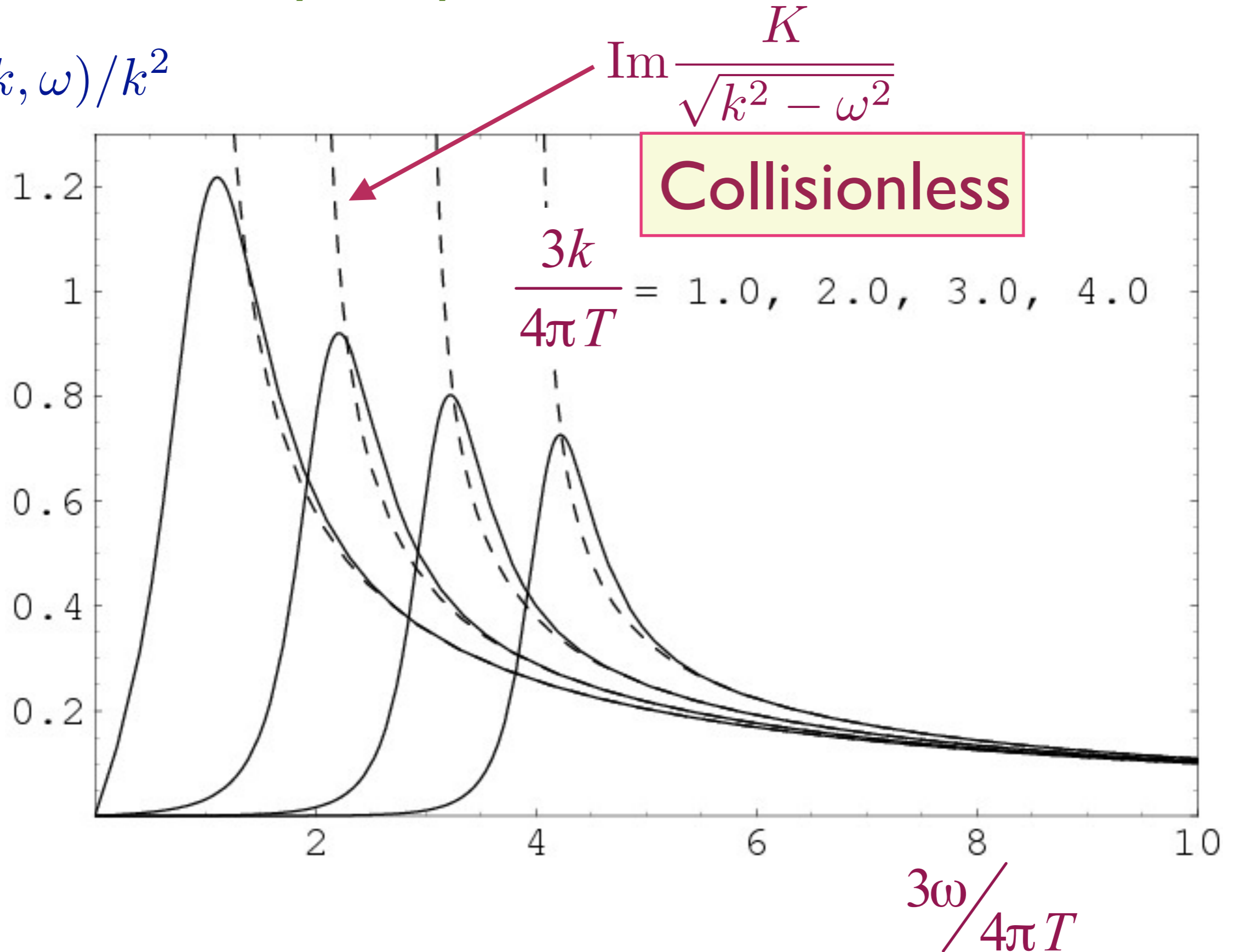

P. Kovtun, C. Herzog, S. Sachdev, and D.T. Son, Phys. Rev. D **75**, 085020 (2007)

# Collisionless to hydrodynamic crossover of SYM3

$$\text{Im}\chi(k, \omega)/k^2$$

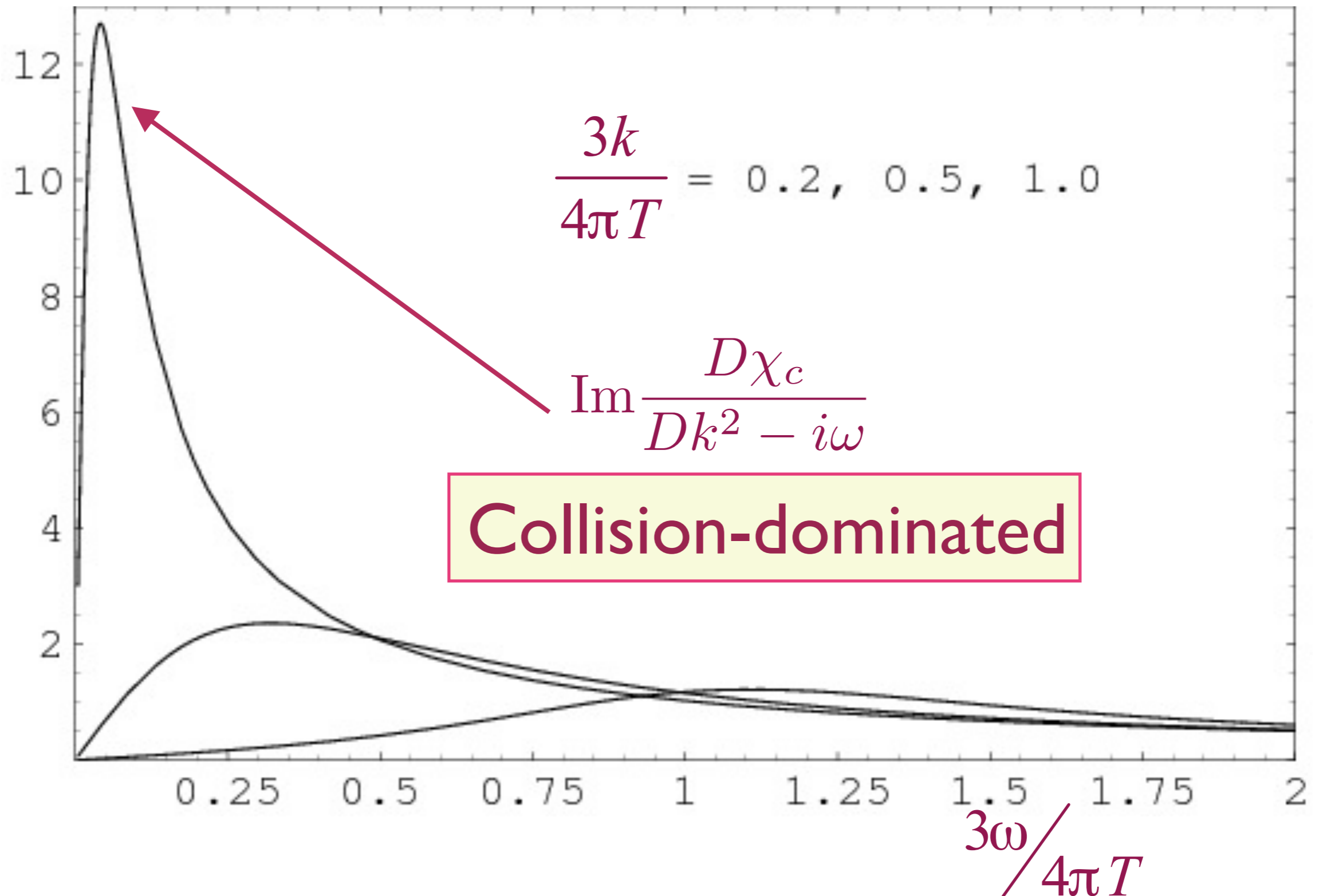

P. Kovtun, C. Herzog, S. Sachdev, and D.T. Son, Phys. Rev. D **75**, 085020 (2007)

# Outline

## 1. The superfluid-insulator transition

*Quantum criticality and  
the AdS/CFT correspondence*

## 2. Graphene

*'Topological' Fermi surface transition*

## 3. The cuprate superconductors

*Fluctuating spin density waves, and  
pairing by "topological" gauge fluctuations*

# Outline

## 1. The superfluid-insulator transition

*Quantum criticality and  
the AdS/CFT correspondence*

## 2. Graphene

*'Topological' Fermi surface transition*

## 3. The cuprate superconductors

*Fluctuating spin density waves, and  
pairing by "topological" gauge fluctuations*

# Graphene

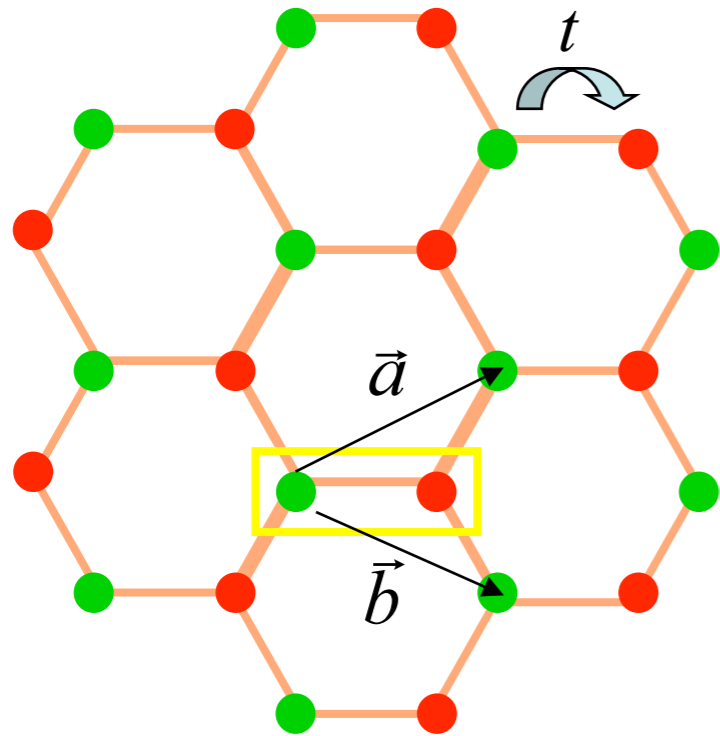

# Graphene

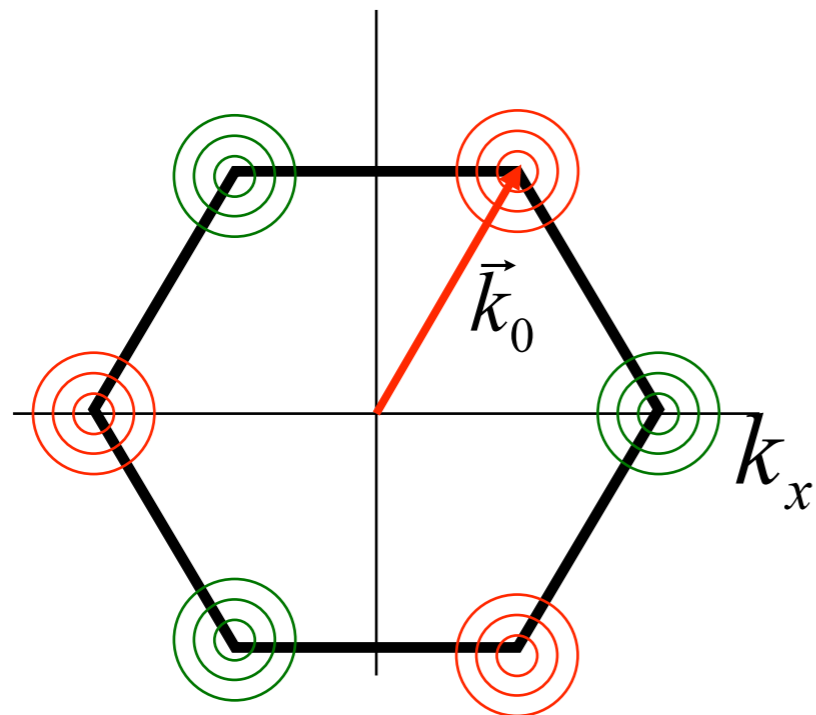
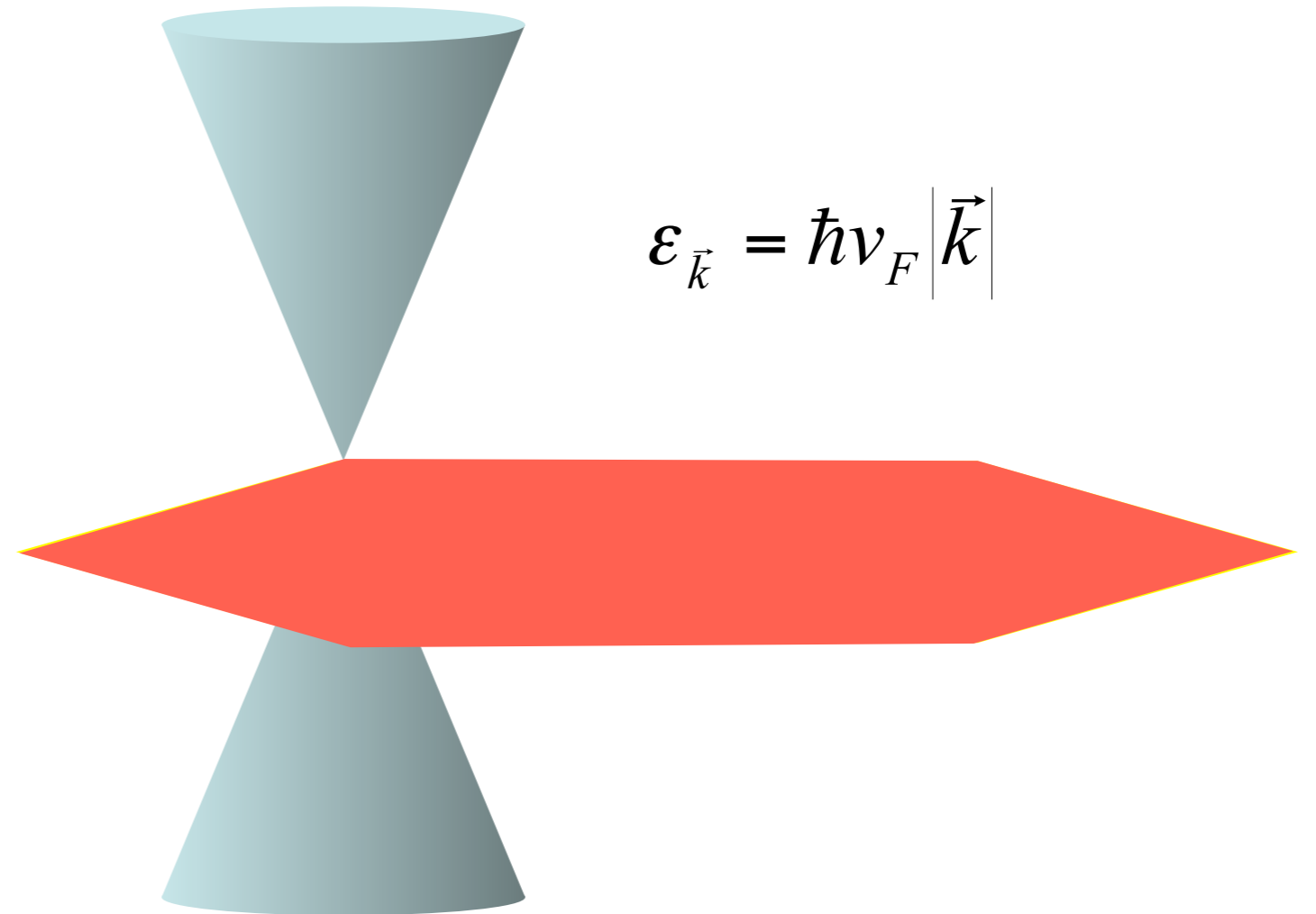
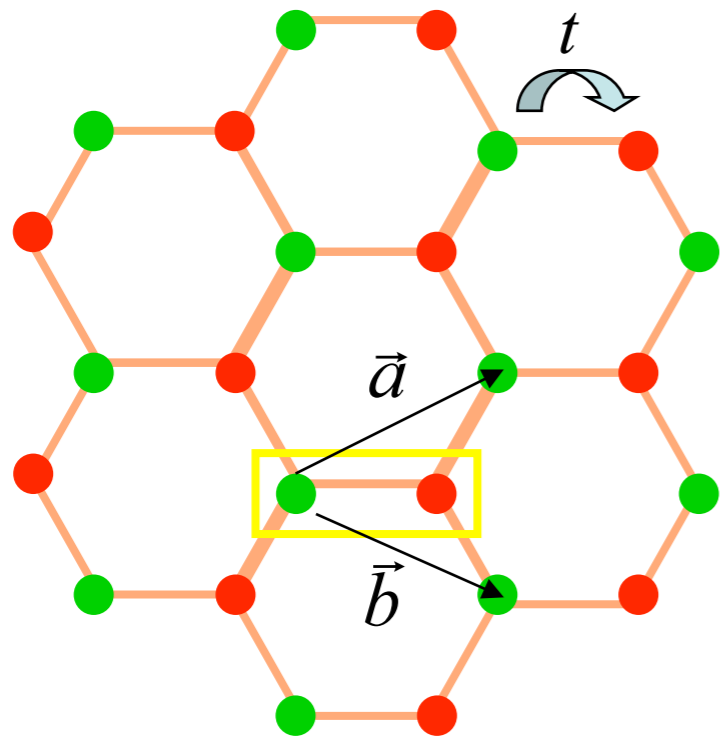

**Conical Dirac dispersion**

# Quantum phase transition in graphene tuned by a gate voltage

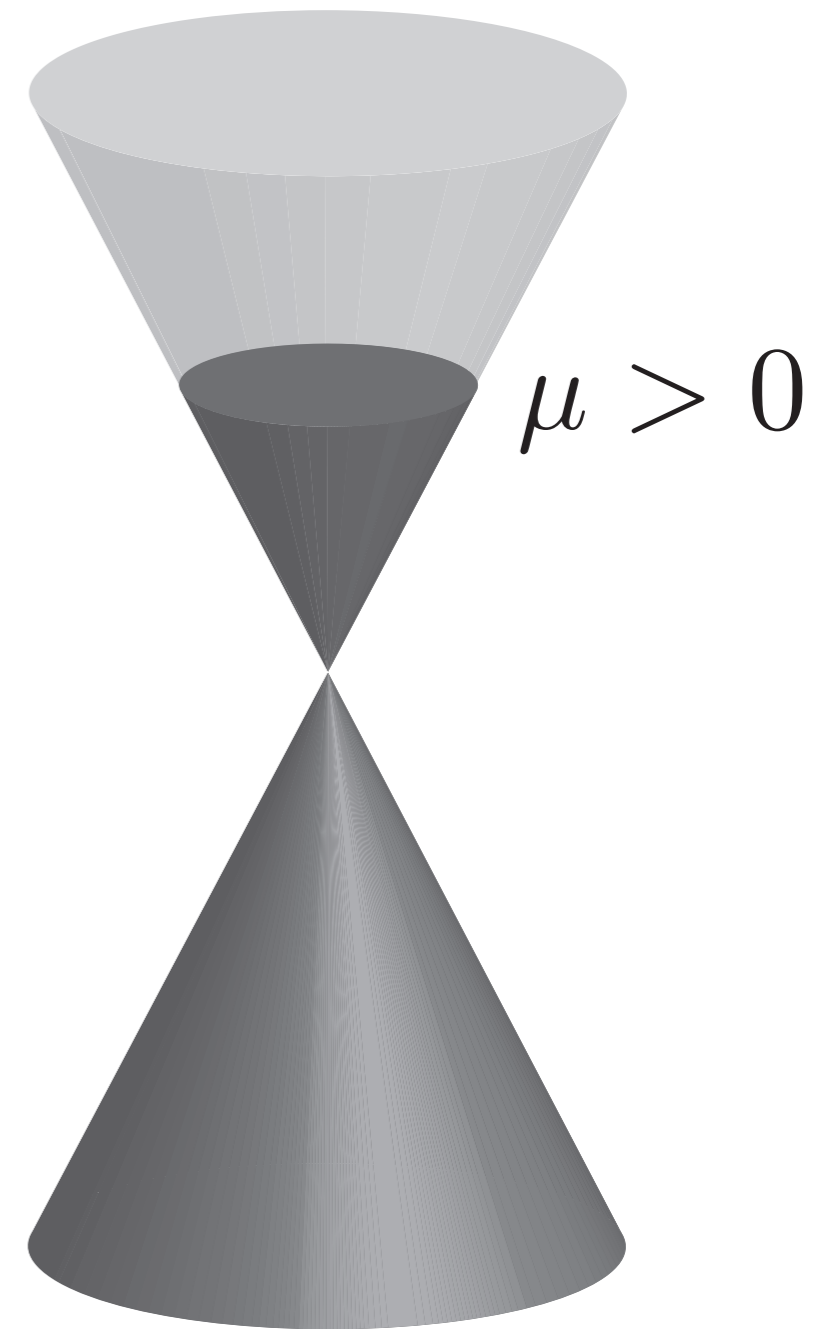

**Electron  
Fermi surface**

# Quantum phase transition in graphene tuned by a gate voltage

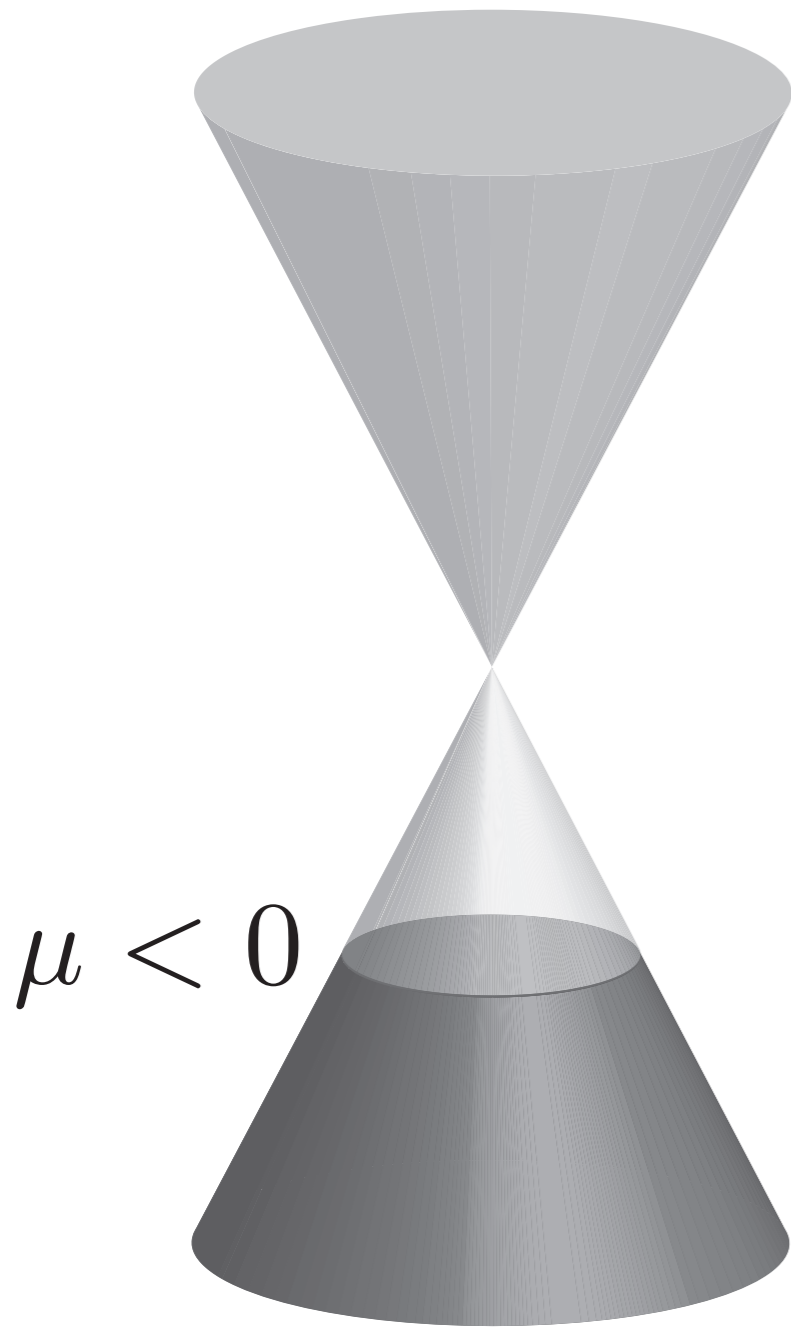

$$\mu < 0$$

**Hole  
Fermi surface**

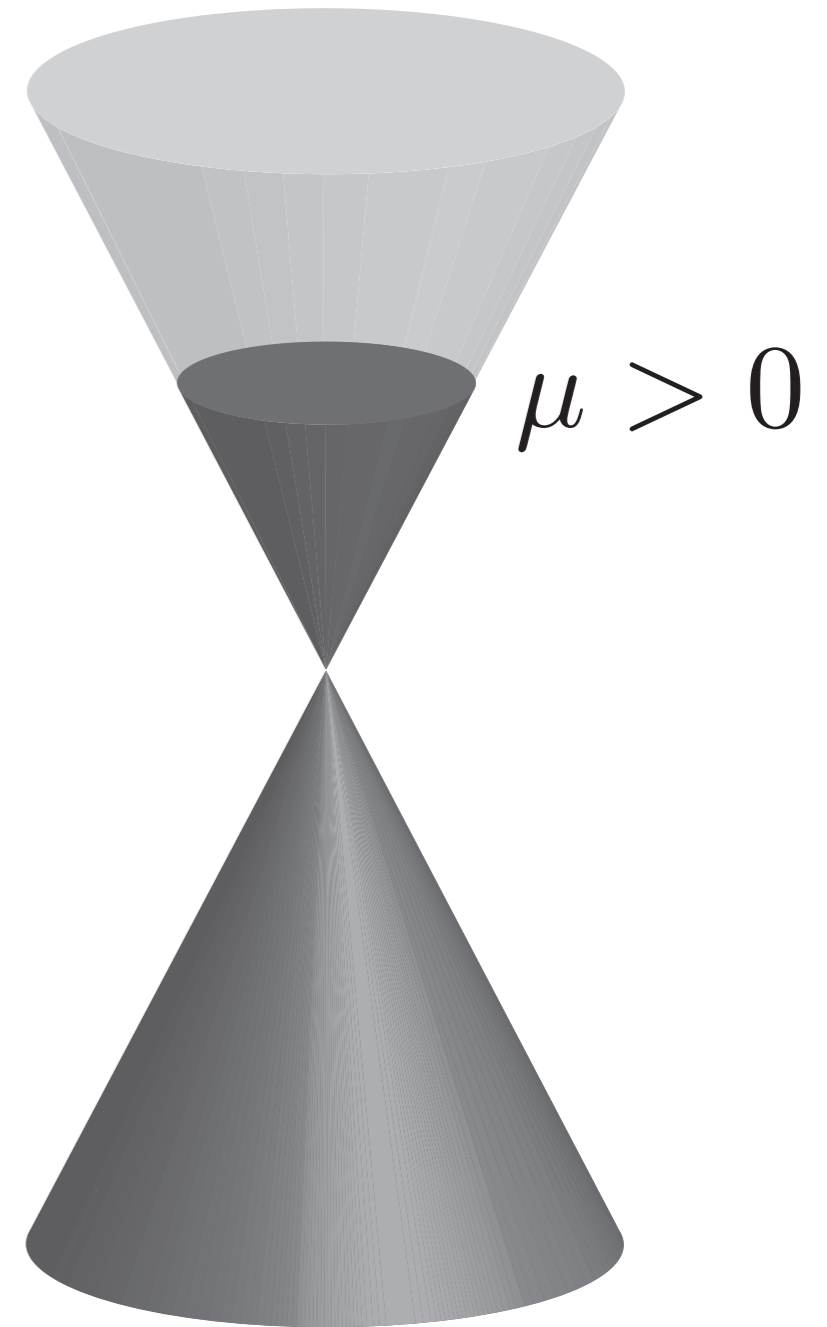

$$\mu > 0$$

**Electron  
Fermi surface**

# Quantum phase transition in graphene tuned by a gate voltage

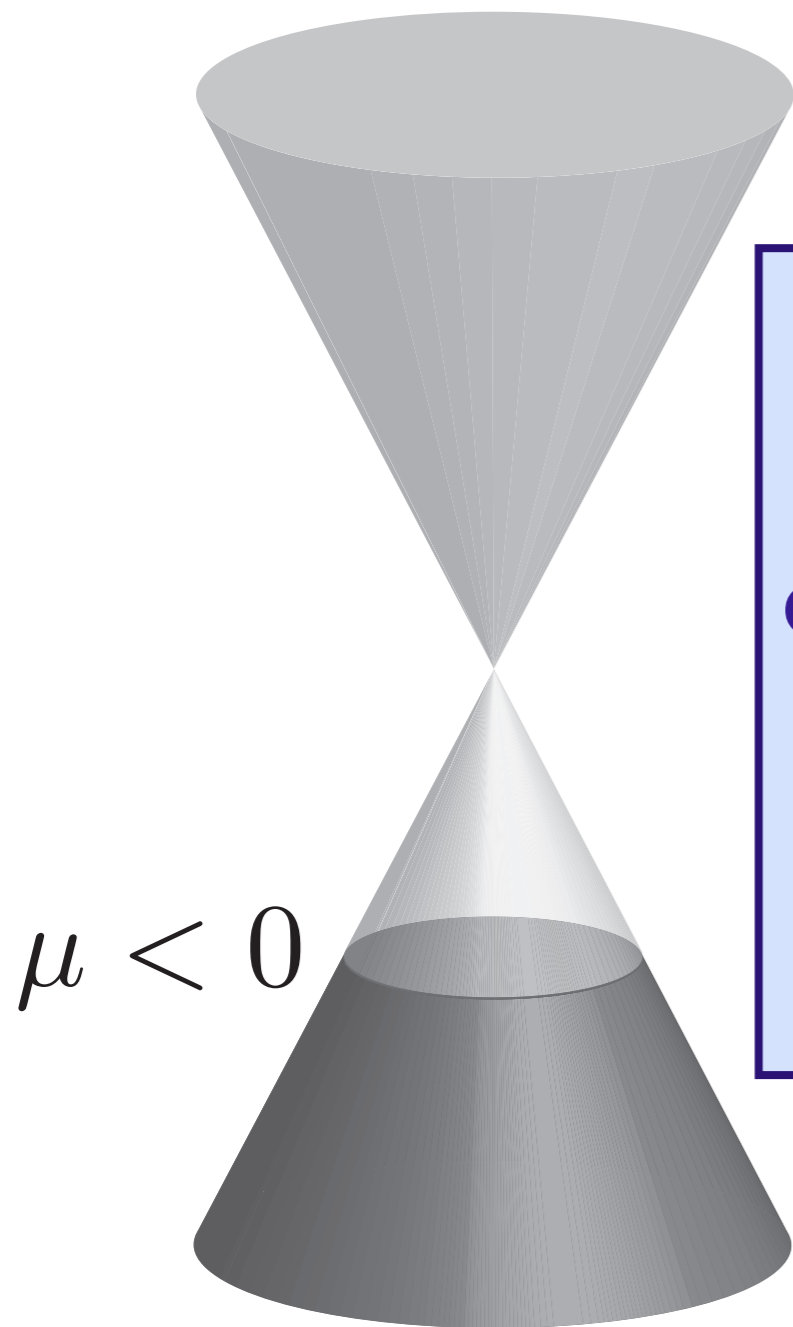

**Hole  
Fermi surface**

There must be an  
intermediate  
quantum critical point  
where the Fermi  
surfaces reduce to a  
Dirac point

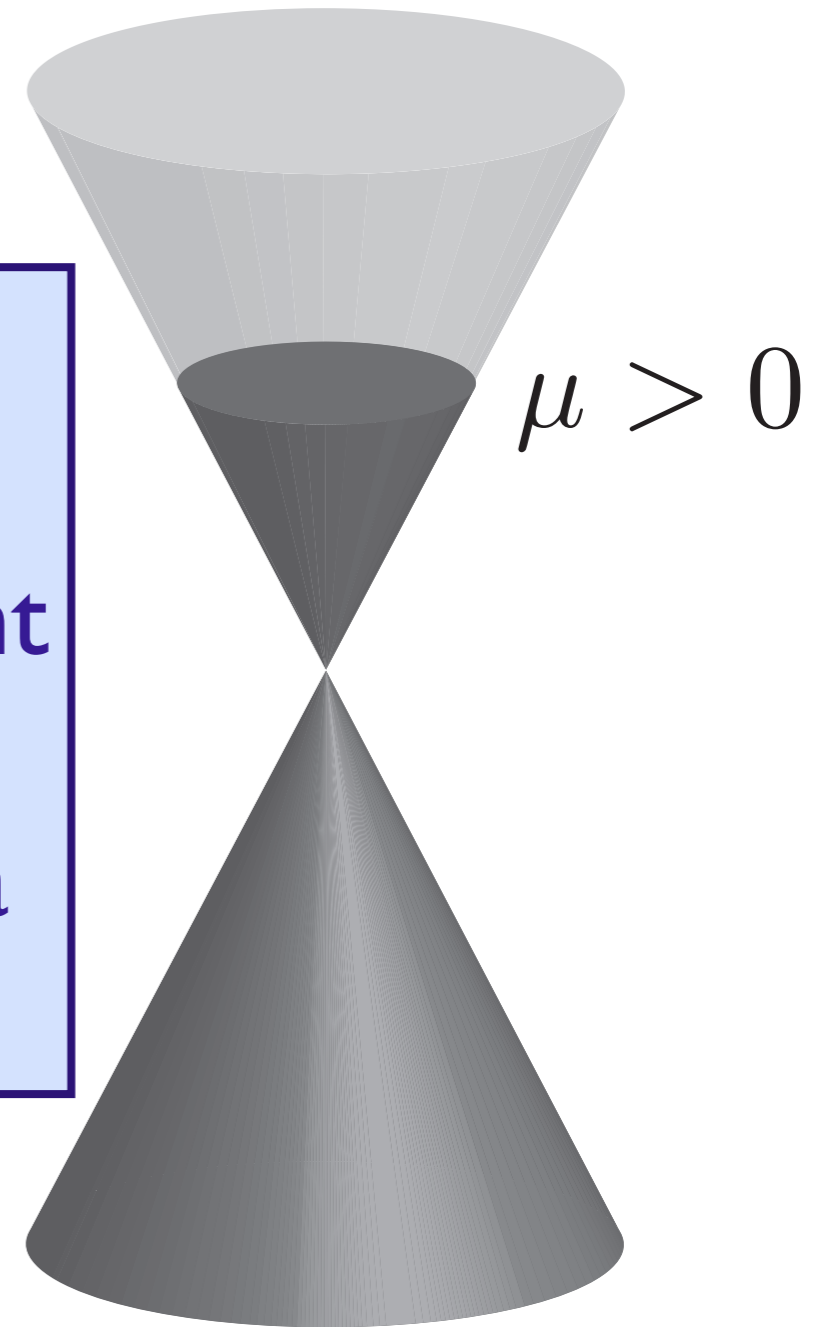

**Electron  
Fermi surface**

# Quantum critical graphene

Low energy theory has 4 two-component Dirac fermions,  $\psi_\sigma$ ,  $\sigma = 1 \dots 4$ , interacting with a  $1/r$  Coulomb interaction

$$\mathcal{S} = \int d^2r d\tau \psi_\sigma^\dagger \left( \partial_\tau - i v_F \vec{\sigma} \cdot \vec{\nabla} \right) \psi_\sigma + \frac{e^2}{2} \int d^2r d^2r' d\tau \psi_\sigma^\dagger \psi_\sigma(r) \frac{1}{|r - r'|} \psi_{\sigma'}^\dagger \psi_{\sigma'}(r')$$

# Quantum critical graphene

Low energy theory has 4 two-component Dirac fermions,  $\psi_\sigma$ ,  $\sigma = 1 \dots 4$ , interacting with a  $1/r$  Coulomb interaction

$$\mathcal{S} = \int d^2r d\tau \psi_\sigma^\dagger \left( \partial_\tau - i v_F \vec{\sigma} \cdot \vec{\nabla} \right) \psi_\sigma + \frac{e^2}{2} \int d^2r d^2r' d\tau \psi_\sigma^\dagger \psi_\sigma(r) \frac{1}{|r - r'|} \psi_{\sigma'}^\dagger \psi_{\sigma'}(r')$$

Dimensionless “fine-structure” constant  $\alpha = e^2 / (\hbar v_F)$ .

RG flow of  $\alpha$ :

$$\frac{d\alpha}{d\ell} = -\alpha^2 + \dots$$

**Behavior is similar to a conformal field theory (CFT) in 2+1 dimensions with  $\alpha \sim 1 / \ln(\text{scale})$**

# Quantum phase transition in graphene

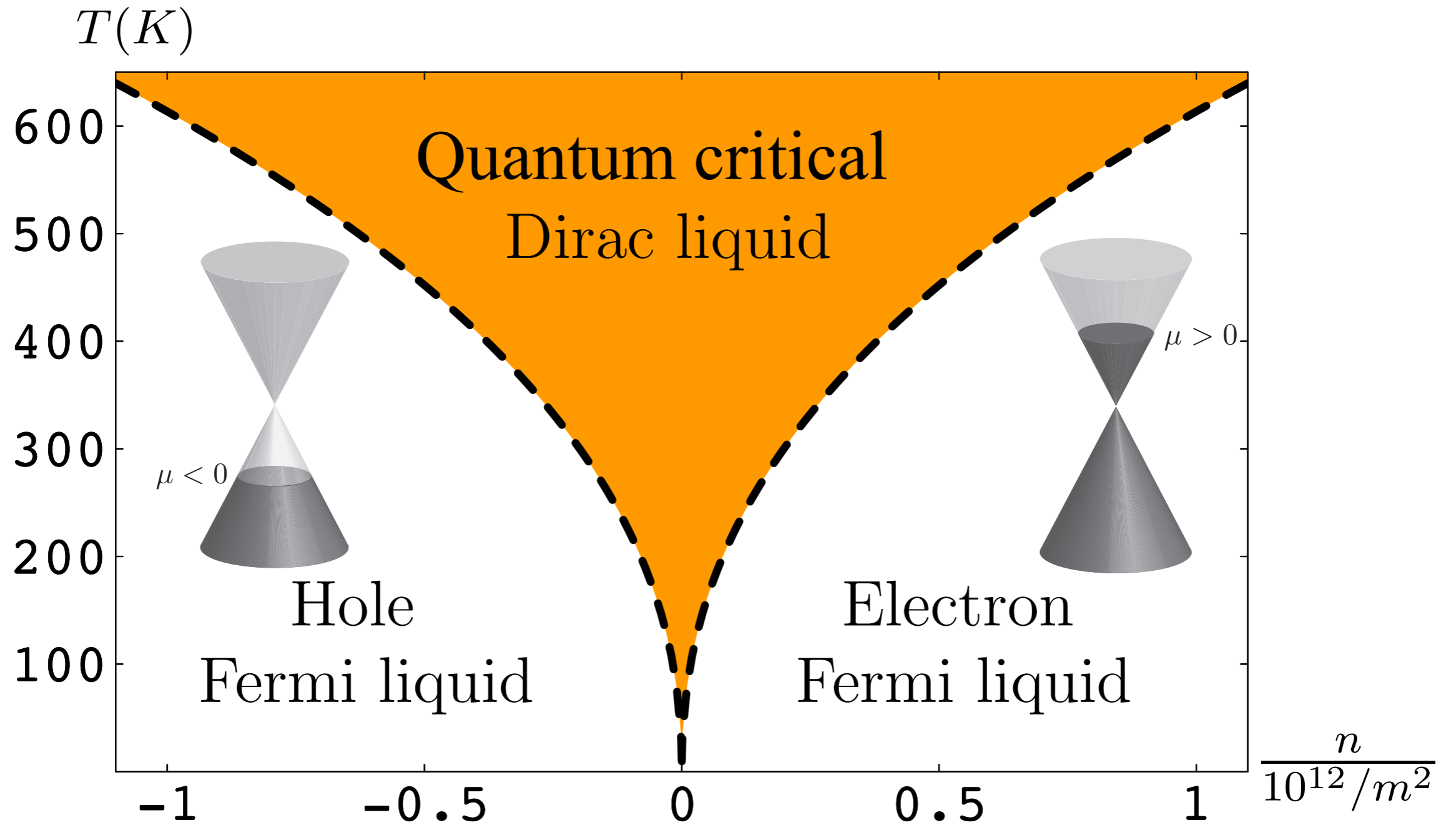

# Quantum critical transport in graphene

$$\sigma(\omega) = \begin{cases} \frac{e^2}{h} \left[ \frac{\pi}{2} + \mathcal{O} \left( \frac{1}{\ln(\Lambda/\omega)} \right) \right] & , \quad \hbar\omega \gg k_B T \\ \frac{e^2}{h\alpha^2(T)} \left[ 0.760 + \mathcal{O} \left( \frac{1}{|\ln(\alpha(T))|} \right) \right] & , \quad \hbar\omega \ll k_B T \alpha^2(T) \end{cases}$$

$$\frac{\eta}{s} = \frac{\hbar}{k_B \alpha^2(T)} \times 0.130$$

where the “fine structure constant” is

$$\alpha(T) = \frac{\alpha}{1 + (\alpha/4) \ln(\Lambda/T)} \stackrel{T \rightarrow 0}{\sim} \frac{4}{\ln(\Lambda/T)}$$

L. Fritz, J. Schmalian, M. Müller and S. Sachdev, *Physical Review B* **78**, 085416 (2008)  
M. Müller, J. Schmalian, and L. Fritz, *Physical Review Letters* **103**, 025301 (2009)

Previously unsolved: general quantum critical transport theory for arbitrary  $\mu$ , applied magnetic field  $B$ , and small impurity density, and general  $\omega/T$ .

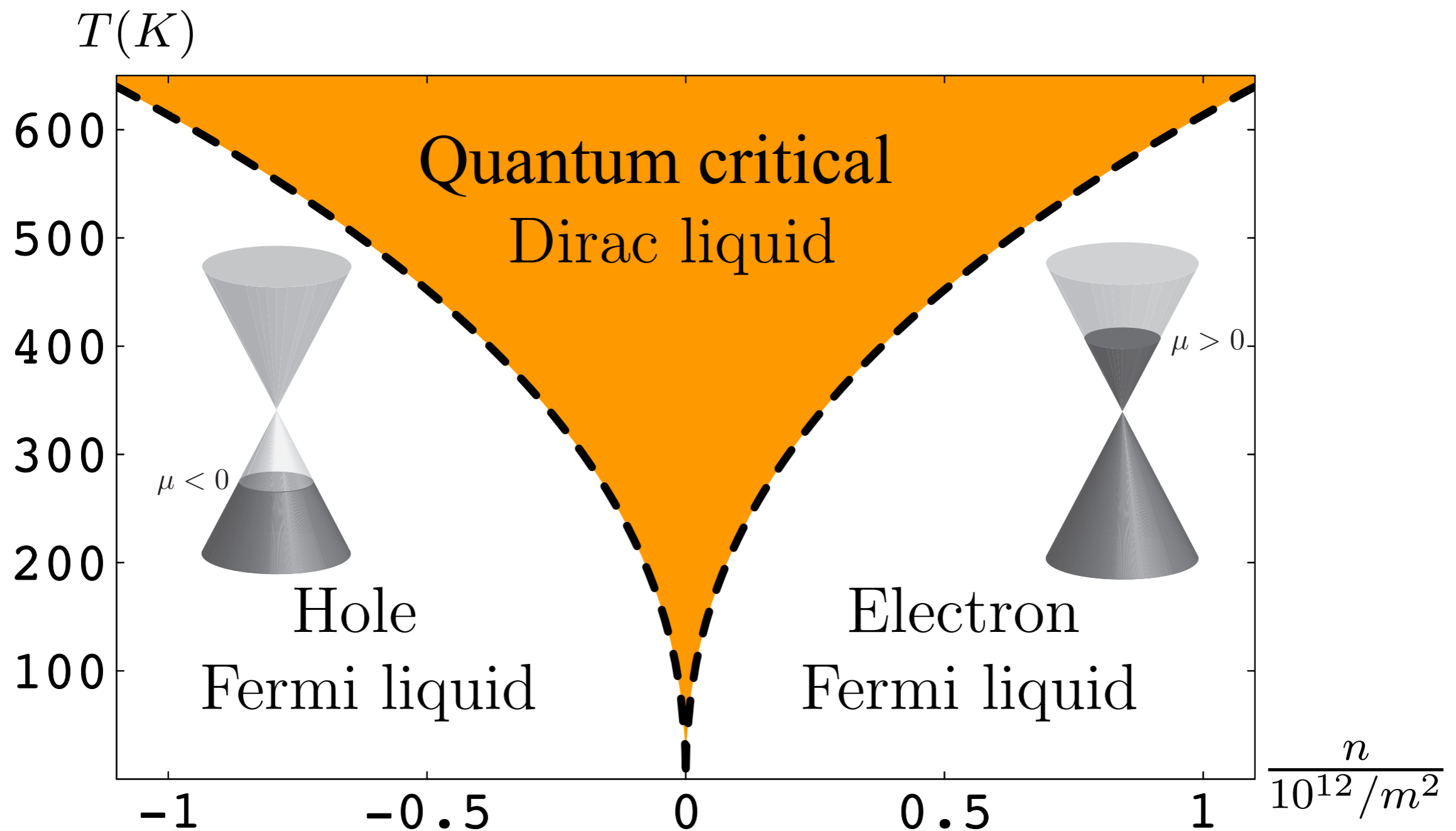

S.A. Hartnoll, P.K. Kovtun, M. Müller, and S. Sachdev, *Phys. Rev. B* **76** 144502 (2007)

Previously unsolved: general quantum critical transport theory for arbitrary  $\mu$ , applied magnetic field  $B$ , and small impurity density, and general  $\omega/T$ .

$\Rightarrow$  maps onto quasinormal modes of a Reissner-Nordstrom black hole in  $\text{AdS}_4$ .

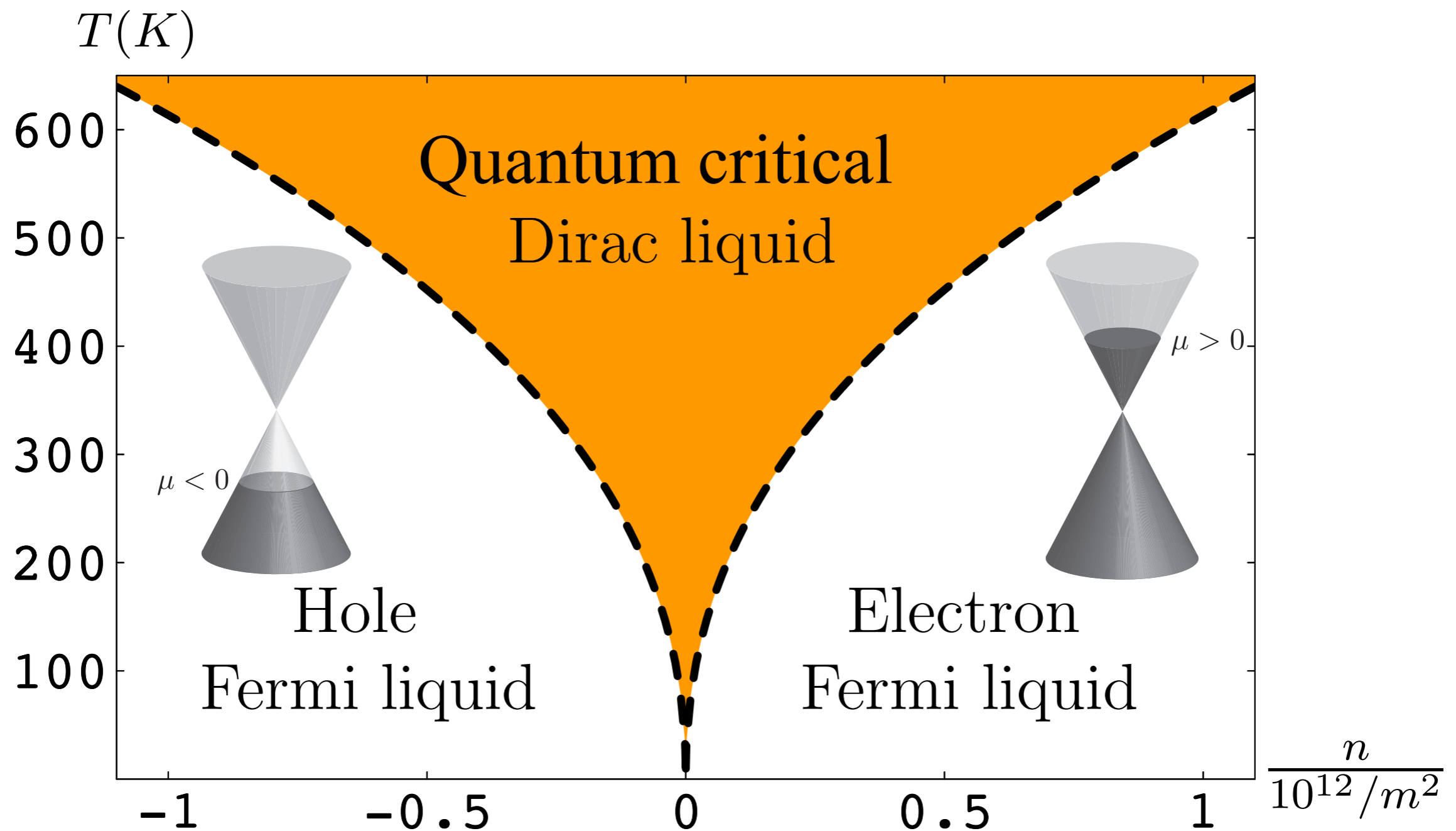

S.A. Hartnoll, P.K. Kovtun, M. Müller, and S. Sachdev, *Phys. Rev. B* **76** 144502 (2007)

# Magnetohydrodynamics of quantum criticality

We used the AdS/CFT connection to derive many new relations between thermoelectric transport co-efficients in the quantum critical regime.

S.A. Hartnoll, P.K. Kovtun, M. Müller, and S. Sachdev, *Phys. Rev. B* **76** 144502 (2007)

# Magnetohydrodynamics of quantum criticality

We used the AdS/CFT connection to derive many new relations between thermoelectric transport co-efficients in the quantum critical regime.

The **same** results were later obtained from the equations of generalized relativistic magnetohydrodynamics, *and* from a solution of the quantum Boltzmann equation.

So the results apply to experiments on graphene, the cuprates, *and* to the dynamics of black holes.

S.A. Hartnoll, P.K. Kovtun, M. Müller, and S. Sachdev, *Phys. Rev. B* **76** 144502 (2007)

# Magnetohydrodynamics of quantum criticality

We used the AdS/CFT connection to derive many new relations between thermoelectric transport co-efficients in the quantum critical regime.

As a simple example, in zero magnetic field, we can write the electrical conductivity as

$$\sigma = \sigma_Q + \frac{e^{*2} \rho^2 v^2}{\varepsilon + P} \pi \delta(\omega)$$

where  $\sigma_Q$  is the universal conductivity of the CFT,  $\rho$  is the charge density,  $\varepsilon$  is the energy density and  $P$  is the pressure.

# Magnetohydrodynamics of quantum criticality

We used the AdS/CFT connection to derive many new relations between thermoelectric transport co-efficients in the quantum critical regime.

The same quantities also determine a “Wiedemann-Franz”-like relation for thermal conductivity,  $\kappa$  at  $B = 0$

$$\kappa = \sigma_Q \left( \frac{k_B^2 T}{e^{*2}} \right) \left( \frac{\varepsilon + P}{k_B T \rho} \right)^2 .$$

At  $B \neq 0$  and  $\rho = 0$  we have a “Wiedemann-Franz” relation for “vortices”

$$\kappa = \frac{1}{\sigma_Q} k_B^2 T \left( \frac{v(\varepsilon + P)}{k_B T B} \right)^2 .$$

# Magnetohydrodynamics of quantum criticality

We used the AdS/CFT connection to derive many new relations between thermoelectric transport co-efficients in the quantum critical regime.

A second example: In an applied magnetic field  $B$ , the dynamic transport co-efficients exhibit a **hydrodynamic cyclotron resonance** at a frequency  $\omega_c$

$$\omega_c = \frac{e^* B \rho v^2}{c(\varepsilon + P)}$$

and damping constant  $\gamma$

$$\gamma = \sigma_Q \frac{B^2 v^2}{c^2(\varepsilon + P)}.$$

The same constants determine the **quasinormal frequency** of the Reissner-Nordstrom black hole.

# Outline

## 1. The superfluid-insulator transition

*Quantum criticality and  
the AdS/CFT correspondence*

## 2. Graphene

*'Topological' Fermi surface transition*

## 3. The cuprate superconductors

*Fluctuating spin density waves, and  
pairing by "topological" gauge fluctuations*

# Outline

## 1. The superfluid-insulator transition

*Quantum criticality and  
the AdS/CFT correspondence*

## 2. Graphene

*'Topological' Fermi surface transition*

## 3. The cuprate superconductors

*Fluctuating spin density waves, and  
pairing by "topological" gauge fluctuations*

# *The cuprate superconductors*

Na-CCOC

- Cu
- Ca/Na
- O
- Cl

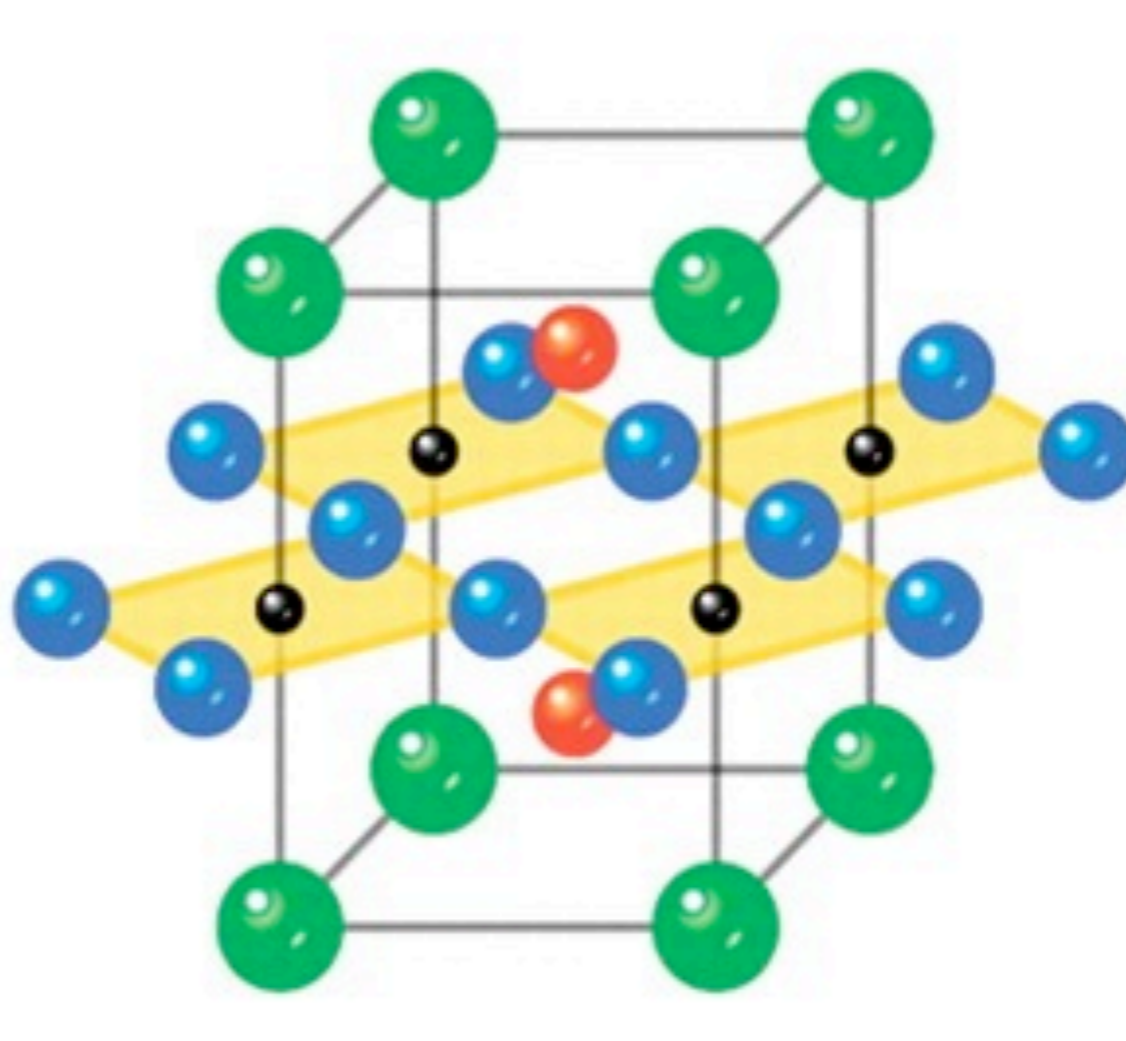

# Central ingredients in cuprate phase diagram: antiferromagnetism, superconductivity, and change in Fermi surface

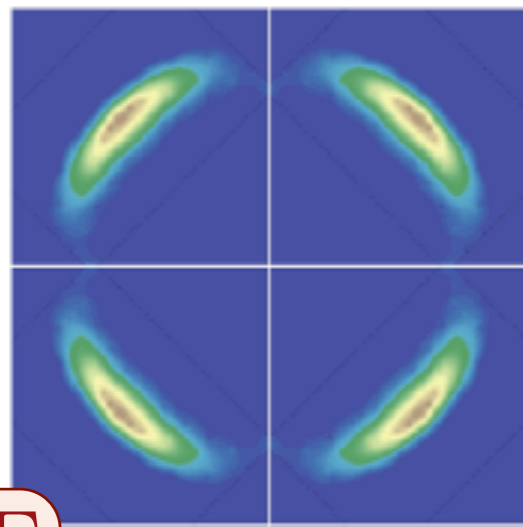

$\Gamma$

*K.M. Shen et al., Science 2005*

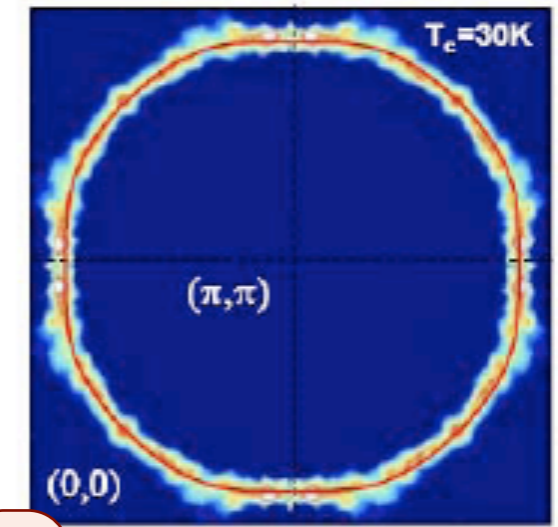
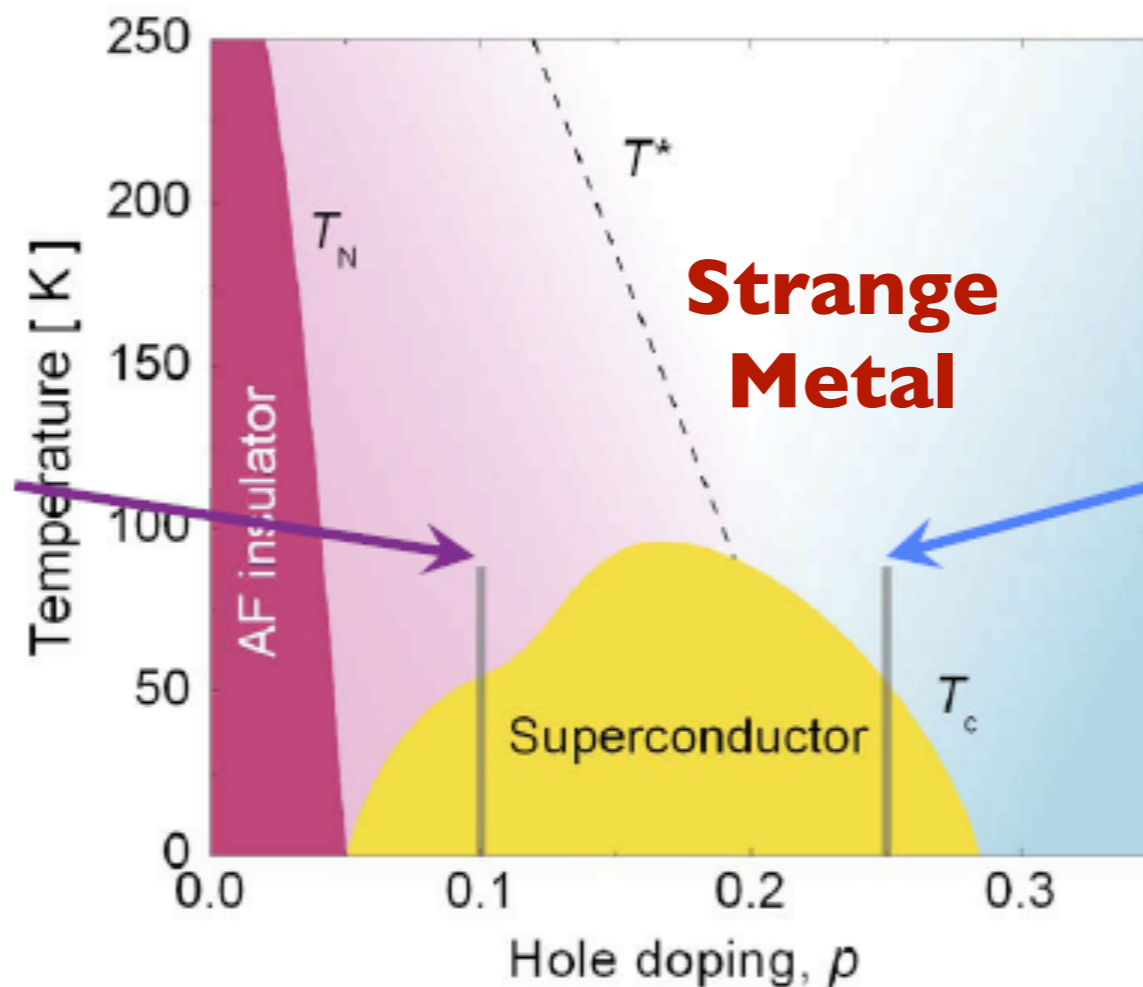

$\Gamma$

*M. Platé et al., PRL 2005*

Smaller hole  
Fermi-pockets

Large hole  
Fermi surface

# Fermi surface+antiferromagnetism

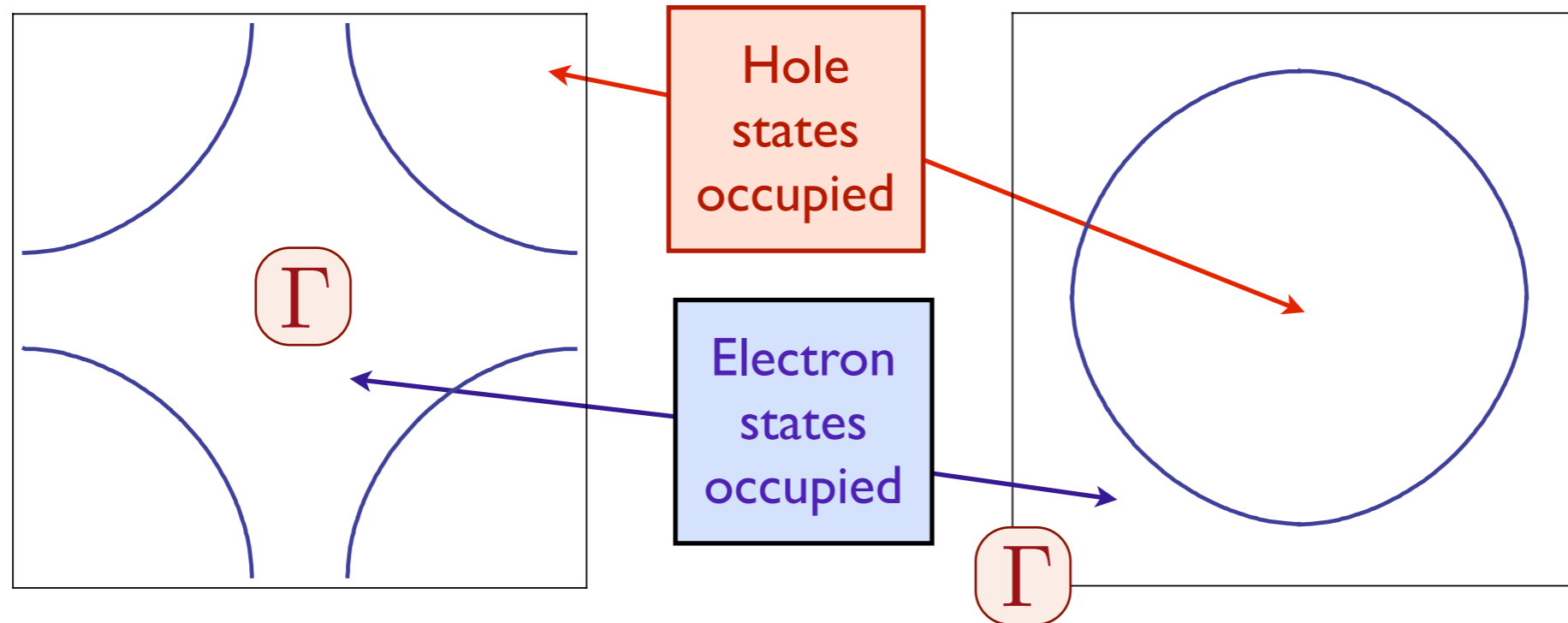

+

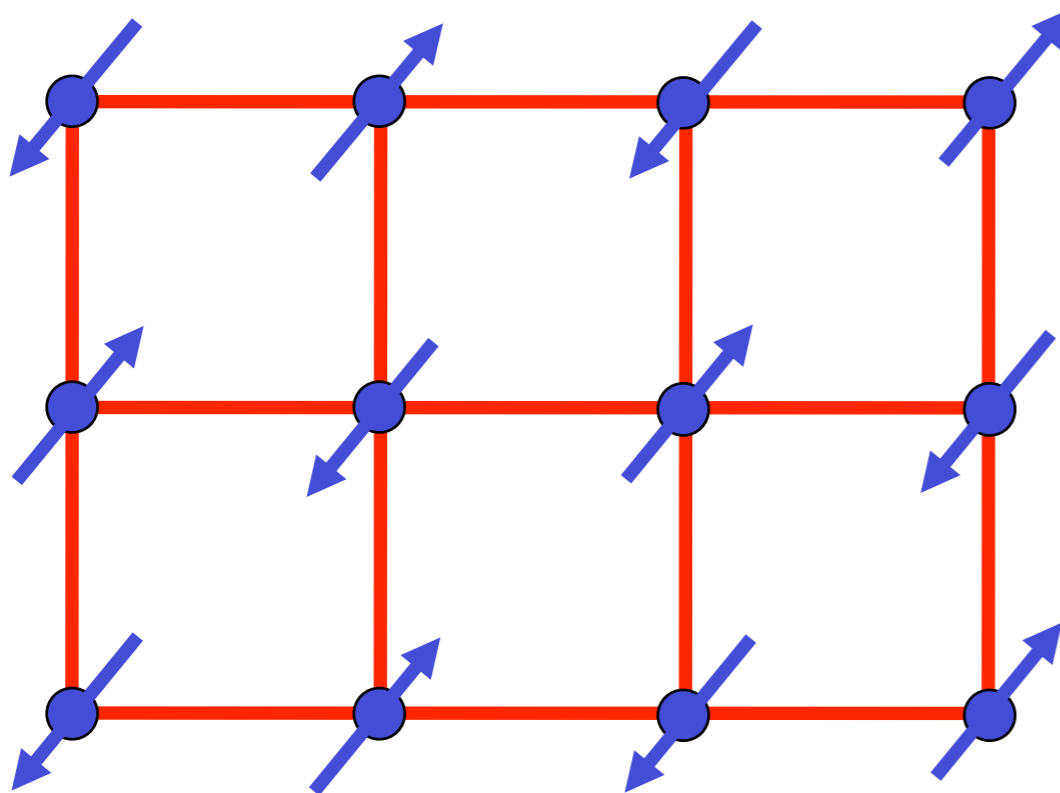

The electron spin polarization obeys

$$\langle \vec{S}(\mathbf{r}, \tau) \rangle = \vec{\varphi}(\mathbf{r}, \tau) e^{i\mathbf{K} \cdot \mathbf{r}}$$

where  $\mathbf{K}$  is the ordering wavevector.

Start from the “spin-fermion” model

$$\begin{aligned}
 \mathcal{Z} &= \int \mathcal{D}c_\alpha \mathcal{D}\vec{\varphi} \exp(-\mathcal{S}) \\
 \mathcal{S} &= \int d\tau \sum_{\mathbf{k}} c_{\mathbf{k}\alpha}^\dagger \left( \frac{\partial}{\partial \tau} - \varepsilon_{\mathbf{k}} \right) c_{\mathbf{k}\alpha} \\
 &\quad - \lambda \int d\tau \sum_i c_{i\alpha}^\dagger \vec{\varphi}_i \cdot \vec{\sigma}_{\alpha\beta} c_{i\beta} e^{i\mathbf{K}\cdot\mathbf{r}_i} \\
 &\quad + \int d\tau d^2r \left[ \frac{1}{2} (\nabla_r \vec{\varphi})^2 + \frac{\tilde{\zeta}}{2} (\partial_\tau \vec{\varphi})^2 + \frac{s}{2} \vec{\varphi}^2 + \frac{u}{4} \vec{\varphi}^4 \right]
 \end{aligned}$$

# Hole-doped cuprates

← Increasing SDW order →

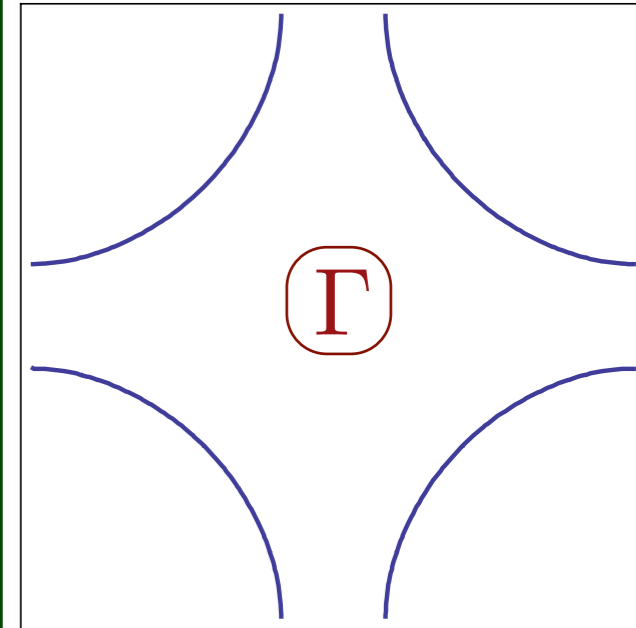

S. Sachdev, A. V. Chubukov, and A. Sokol, *Phys. Rev. B* **51**, 14874 (1995).  
A. V. Chubukov and D. K. Morr, *Physics Reports* **288**, 355 (1997).

# Hole-doped cuprates

← Increasing SDW order →

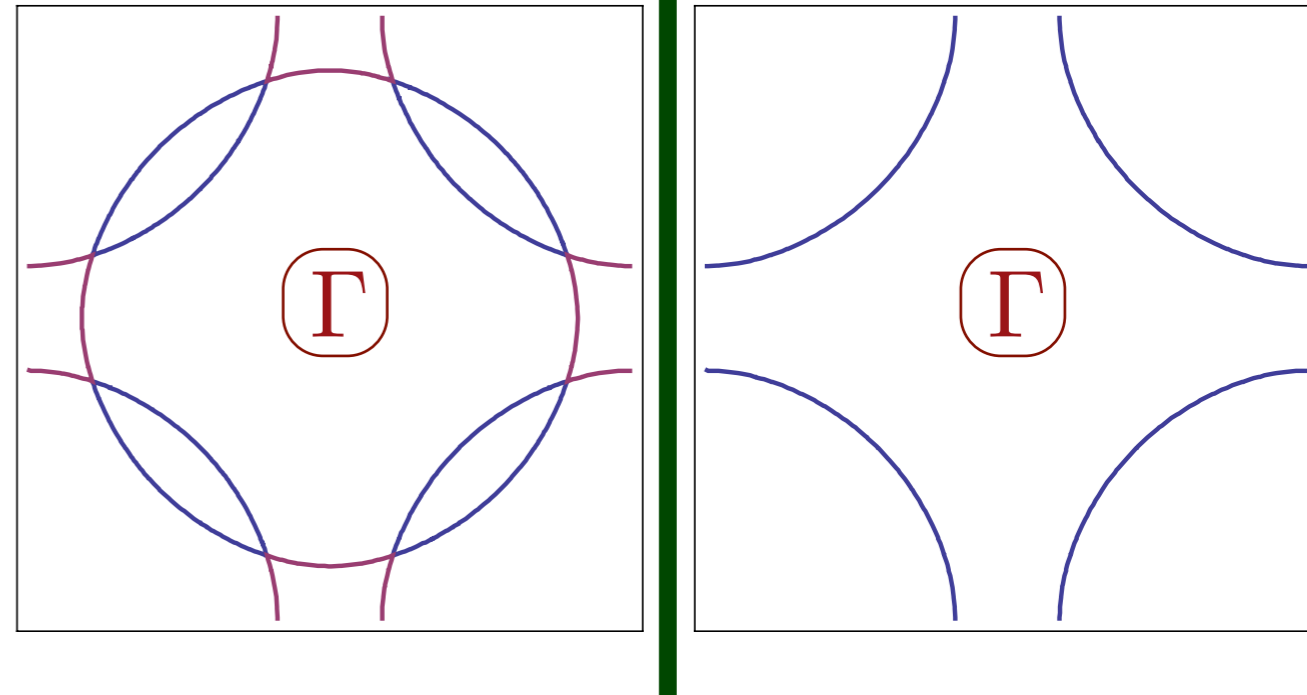

S. Sachdev, A. V. Chubukov, and A. Sokol, *Phys. Rev. B* **51**, 14874 (1995).  
A. V. Chubukov and D. K. Morr, *Physics Reports* **288**, 355 (1997).

# Hole-doped cuprates

← Increasing SDW order →

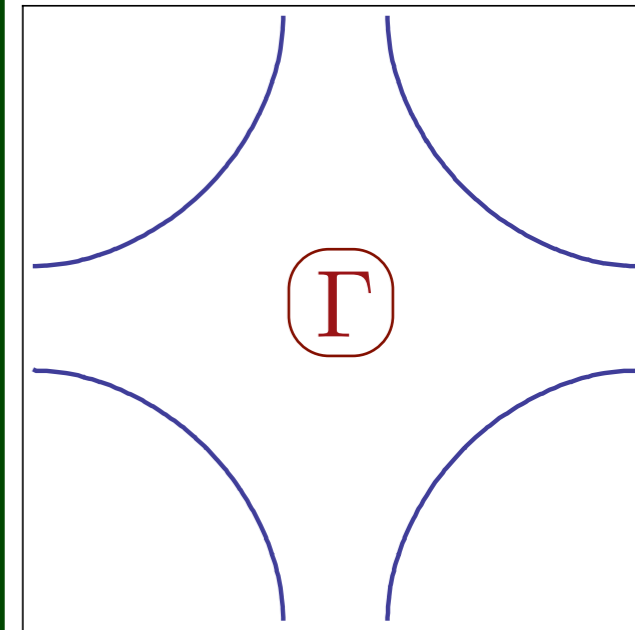
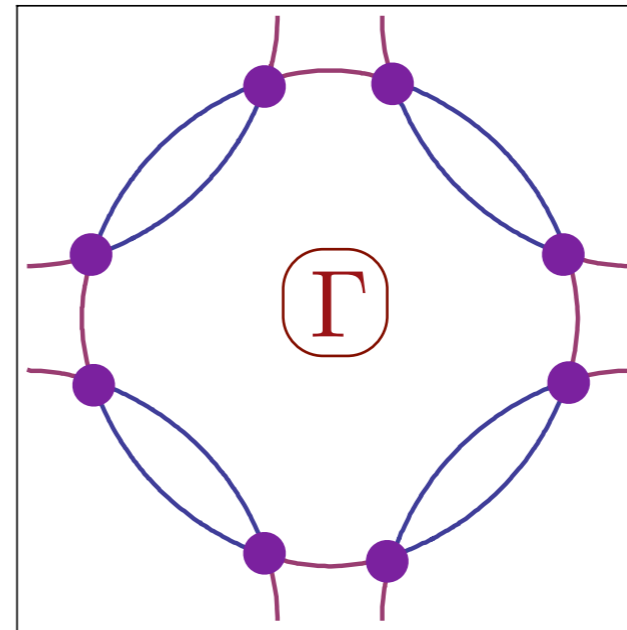

Hot spots

S. Sachdev, A. V. Chubukov, and A. Sokol, *Phys. Rev. B* **51**, 14874 (1995).  
A. V. Chubukov and D. K. Morr, *Physics Reports* **288**, 355 (1997).

# Hole-doped cuprates

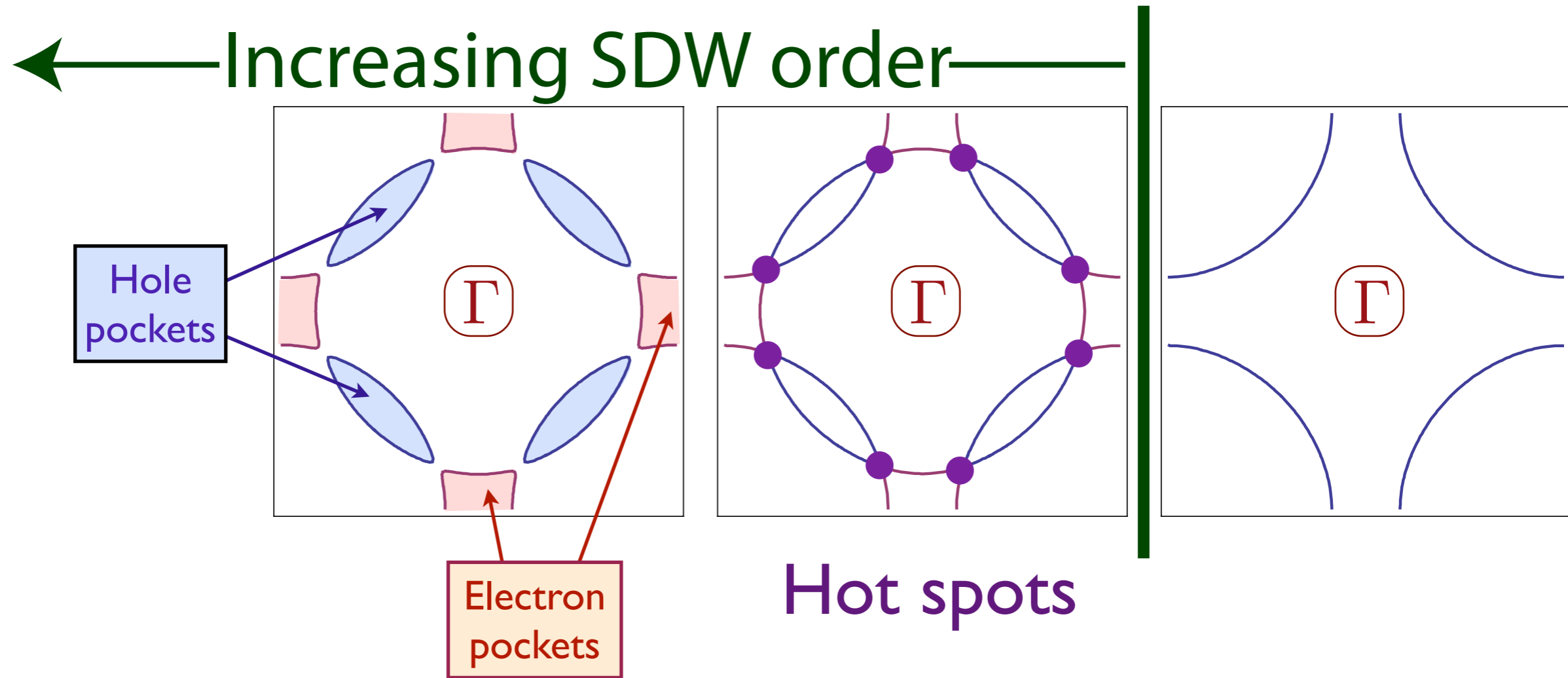

Fermi surface breaks up at hot spots  
into electron and hole “pockets”

S. Sachdev, A. V. Chubukov, and A. Sokol, *Phys. Rev. B* **51**, 14874 (1995).  
A. V. Chubukov and D. K. Morr, *Physics Reports* **288**, 355 (1997).

# Hole-doped cuprates

← Increasing SDW order →

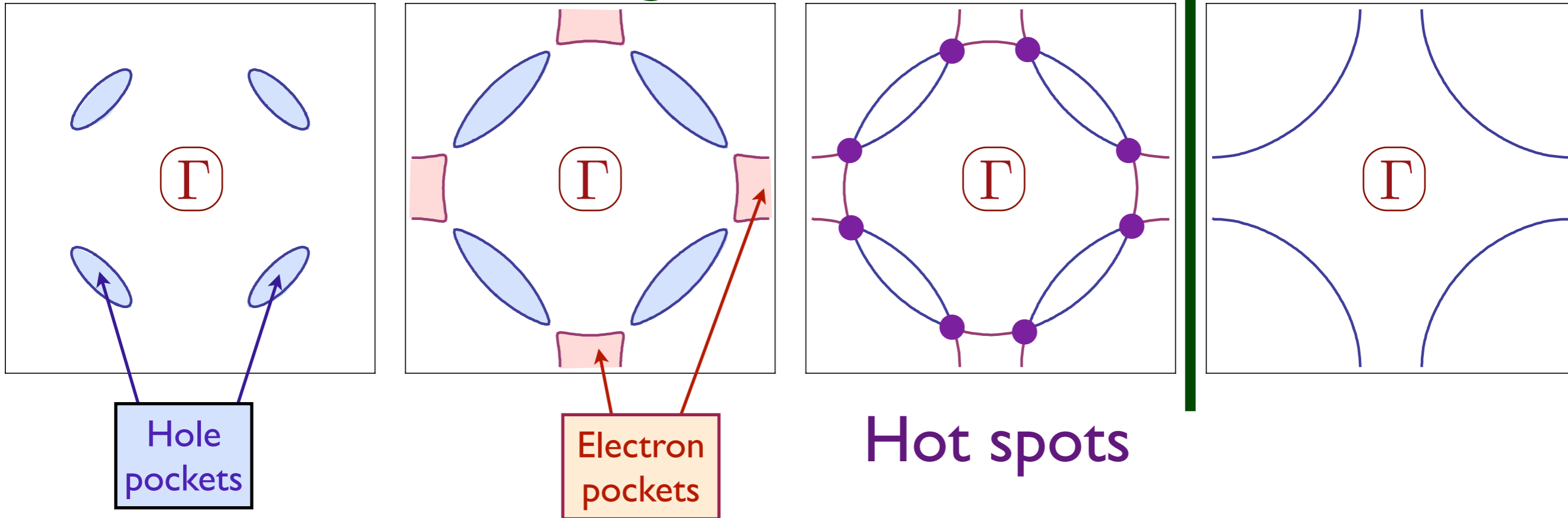

Fermi surface breaks up at hot spots  
into electron and hole “pockets”

S. Sachdev, A. V. Chubukov, and A. Sokol, *Phys. Rev. B* **51**, 14874 (1995).  
A. V. Chubukov and D. K. Morr, *Physics Reports* **288**, 355 (1997).

# Evidence for small Fermi pockets

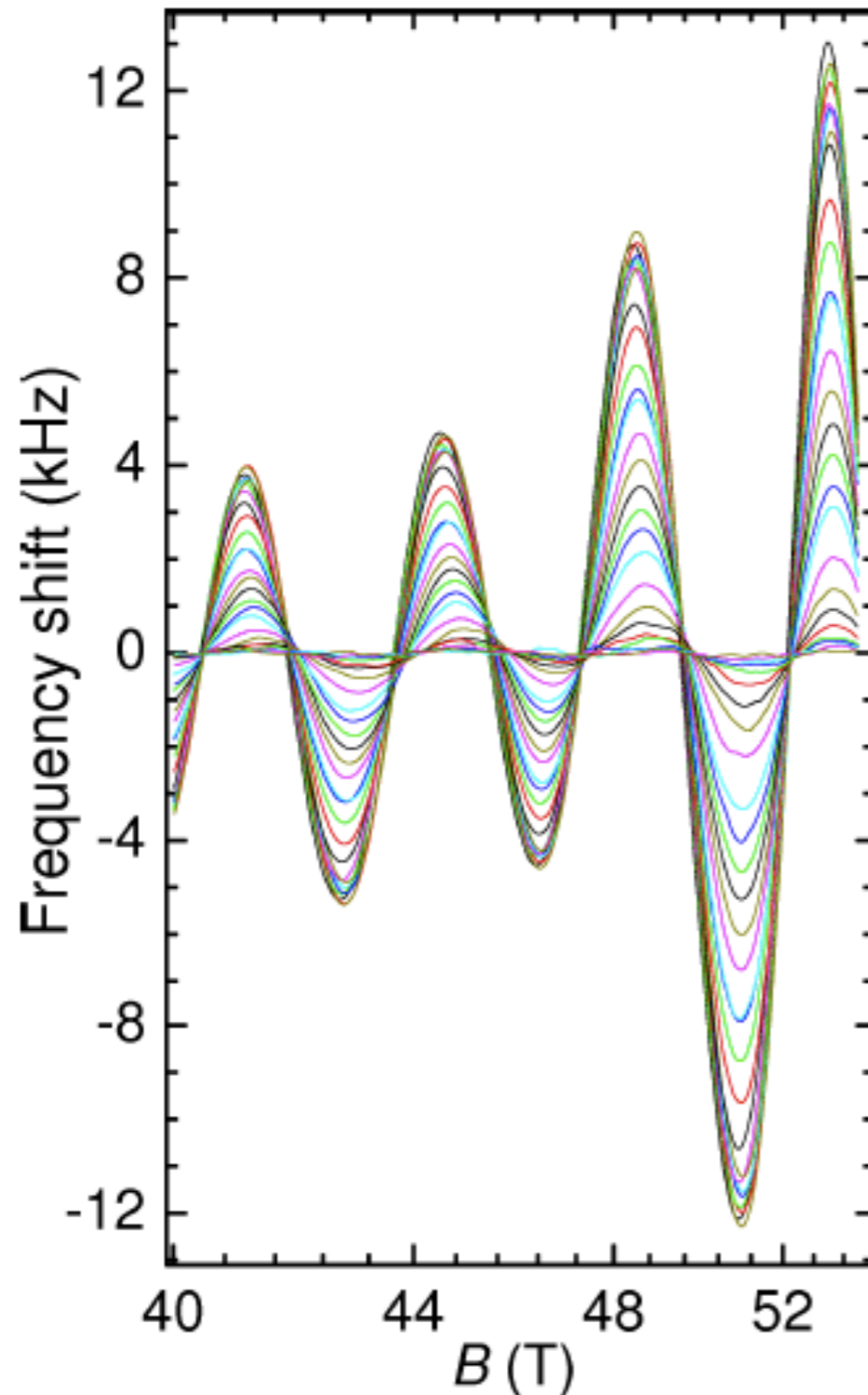

## Fermi liquid behaviour in an underdoped high $T_c$ superconductor

Suchitra E. Sebastian, N. Harrison,  
M. M. Altarawneh, Ruixing Liang, D. A. Bonn,  
W. N. Hardy, and G. G. Lonzarich

arXiv:0912.3022

FIG. 2: Magnetic quantum oscillations measured in  $\text{YBa}_2\text{Cu}_3\text{O}_{6+x}$  with  $x \approx 0.56$  (after background polynomial subtraction). This restricted interval in  $B = |\mathbf{B}|$  furnishes a dynamic range of  $\sim 50$  dB between  $T = 1$  and 18 K. The actual  $T$  values are provided in Fig. 3.

# Theory of underdoped cuprates

← Increasing SDW order →

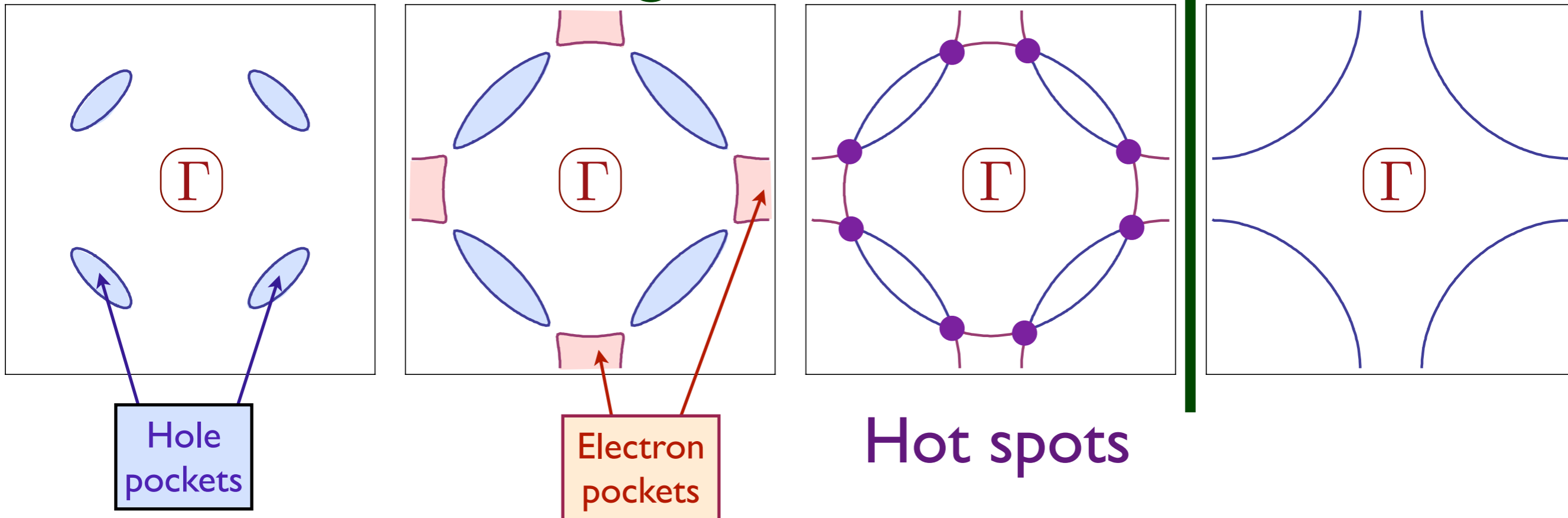

Fermi surface breaks up at hot spots  
into electron and hole “pockets”

S. Sachdev, A. V. Chubukov, and A. Sokol, *Phys. Rev. B* **51**, 14874 (1995).  
A. V. Chubukov and D. K. Morr, *Physics Reports* **288**, 355 (1997).

# Theory of underdoped cuprates

← Increasing SDW order →

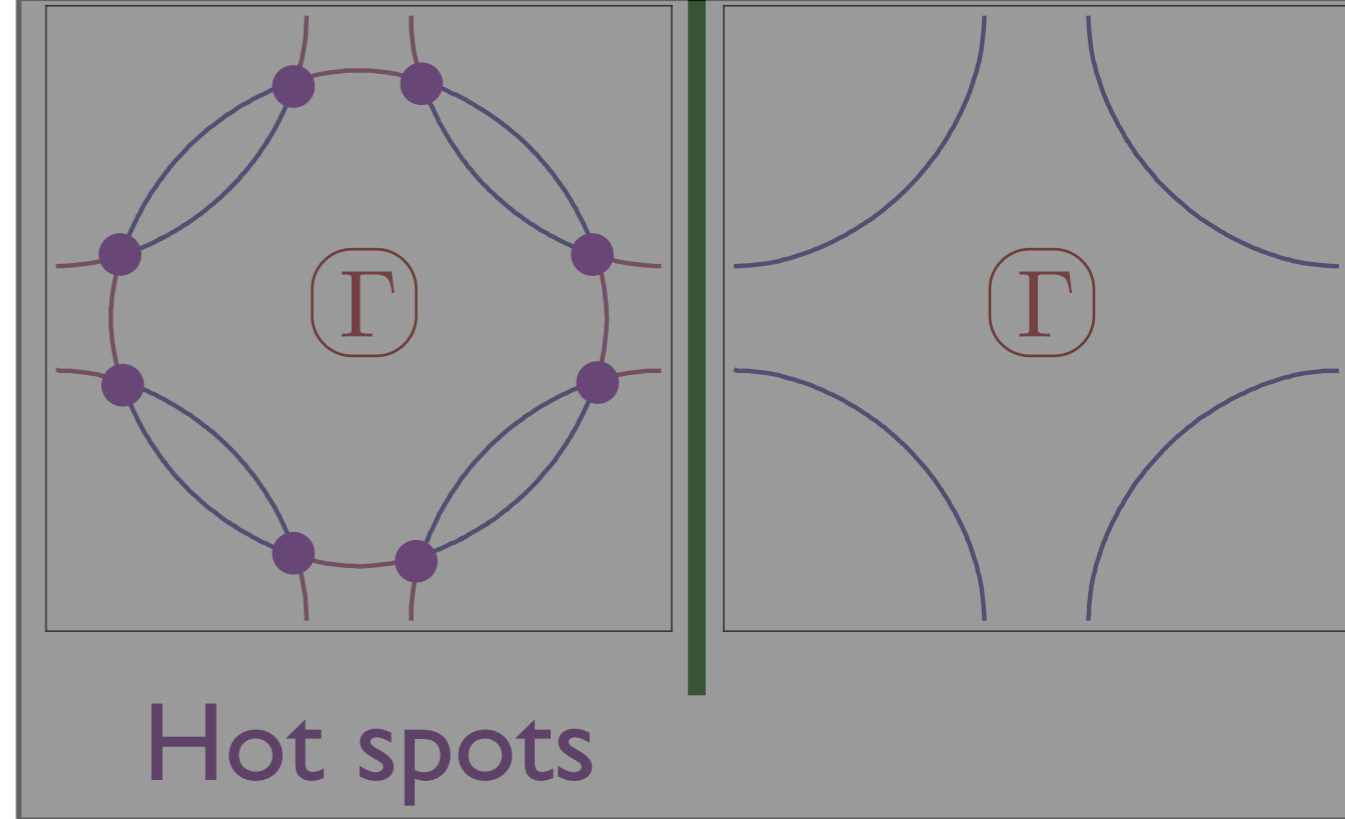
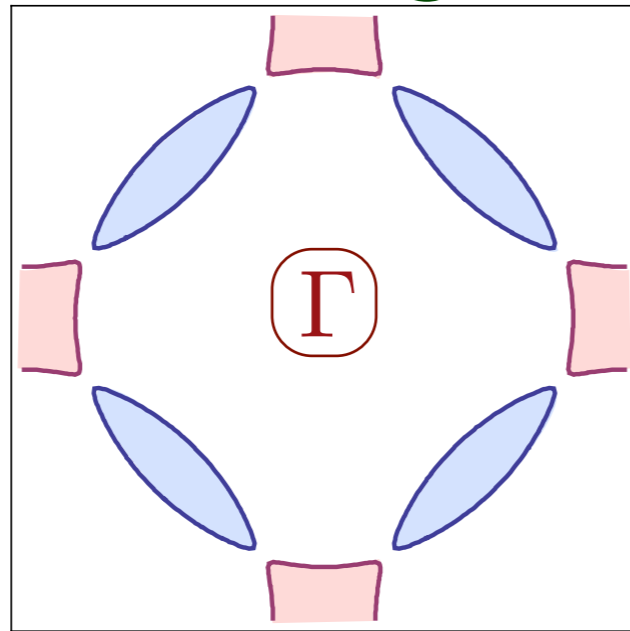
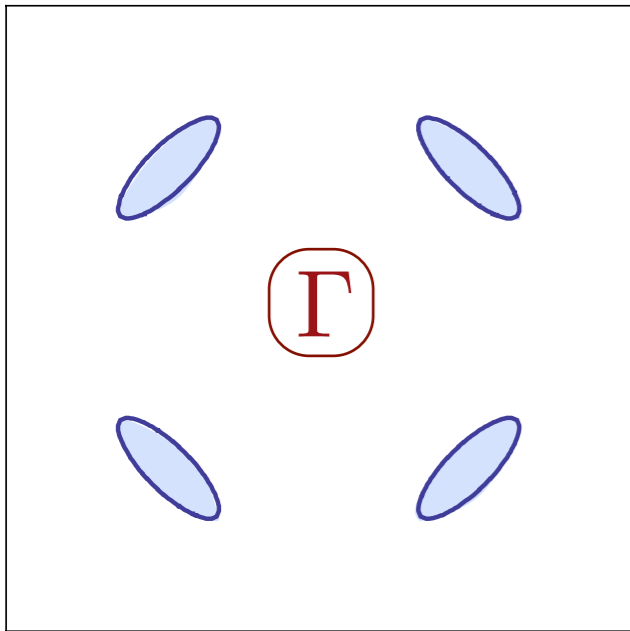

Begin with SDW ordered state, and rotate to a frame polarized along the local orientation of the SDW order  $\hat{\varphi}$

$$\begin{pmatrix} c_{\uparrow} \\ c_{\downarrow} \end{pmatrix} = R \begin{pmatrix} \psi_{+} \\ \psi_{-} \end{pmatrix} ; \quad R^{\dagger} \hat{\varphi} \cdot \vec{\sigma} R = \sigma^z ; \quad R^{\dagger} R = 1$$

H. J. Schulz, *Physical Review Letters* **65**, 2462 (1990)

B. I. Shraiman and E. D. Siggia, *Physical Review Letters* **61**, 467 (1988).

J. R. Schrieffer, *Journal of Superconductivity* **17**, 539 (2004)

# Theory of underdoped cuprates

$$\text{With } R = \begin{pmatrix} z_{\uparrow} & -z_{\downarrow}^* \\ z_{\downarrow} & z_{\uparrow}^* \end{pmatrix} \text{ or } \hat{\vec{\varphi}} = z_{\alpha}^* \vec{\sigma}_{\alpha\beta} z_{\beta}$$

the theory is invariant under

$$z_{\alpha} \rightarrow e^{i\theta} z_{\alpha} ; \psi_{+} \rightarrow e^{-i\theta} \psi_{+} ; \psi_{-} \rightarrow e^{i\theta} \psi_{-}$$

We obtain a U(1) gauge theory of

- bosonic neutral spinons  $z_{\alpha}$ ;
- spinless, charged fermions  $\psi_{\pm}$  with small ‘pocket’ Fermi surfaces;
- an emergent U(1) gauge field  $A_{\mu}$ .

S. Sachdev, M. A. Metlitski, Y. Qi, and C. Xu, *Phys. Rev. B* **80**, 155129 (2009).

- Begin with a CFT3: the  $CP^1$  model.

$$\mathcal{L}_z = \frac{1}{\gamma} |(\partial_\mu - iA_\mu)z_\alpha|^2 \quad ; \quad |z_\alpha|^2 = 1$$

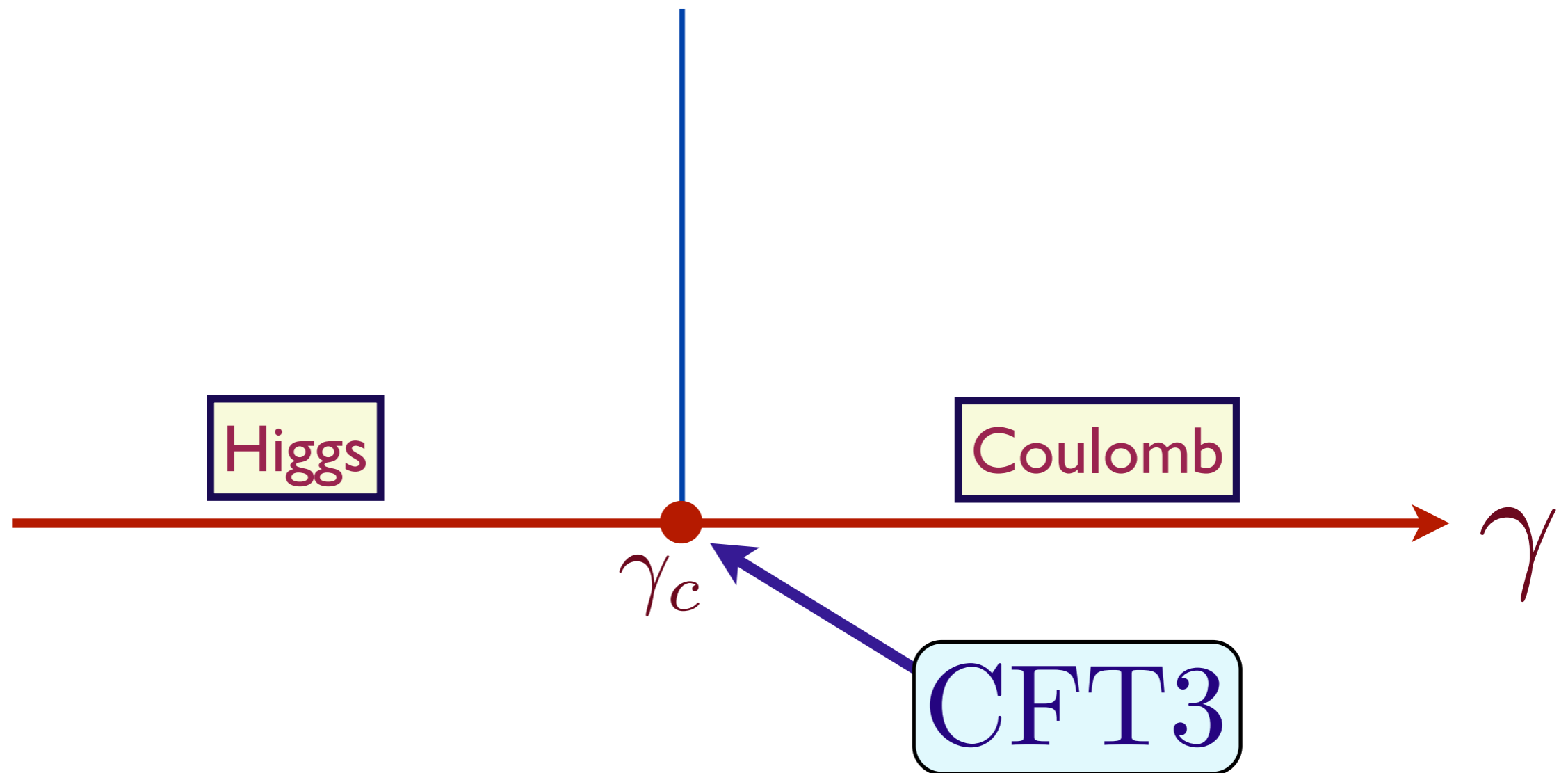

- Begin with a CFT3: the  $CP^1$  model.

$$\mathcal{L}_z = \frac{1}{\gamma} |(\partial_\mu - iA_\mu)z_\alpha|^2 \quad ; \quad |z_\alpha|^2 = 1$$

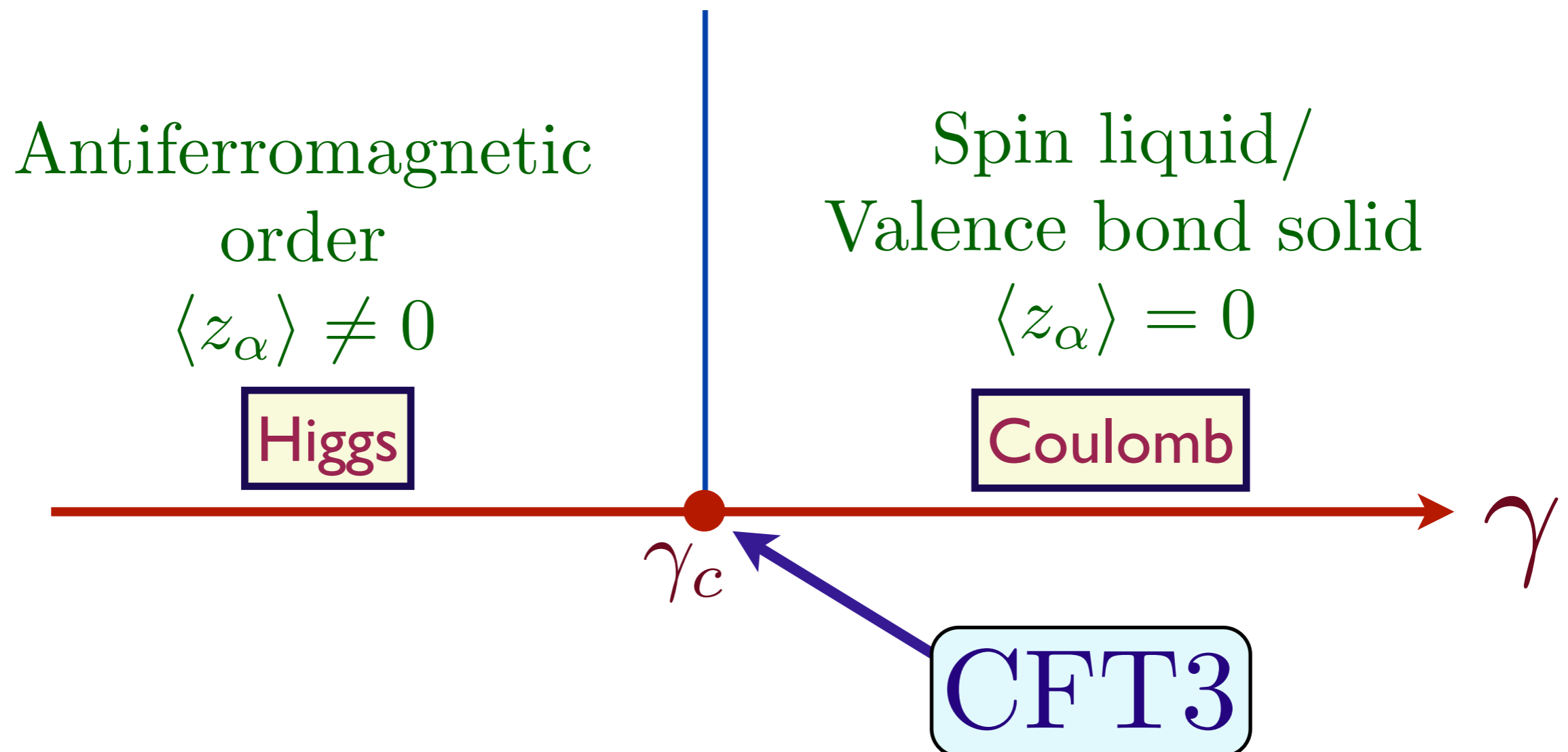

- Begin with a CFT3: the  $CP^1$  model.
- Add “probe” non-relativistic fermions,  $g_+$  and  $g_-$ , with opposite gauge charges

$$\mathcal{L}_f = g_+^\dagger \left( \frac{\partial}{\partial \tau} - iA_\tau - \frac{1}{2m} \left( \vec{\nabla} - i\vec{A} \right)^2 \right) g_+ + g_-^\dagger \left( \frac{\partial}{\partial \tau} + iA_\tau - \frac{1}{2m} \left( \vec{\nabla} + i\vec{A} \right)^2 \right) g_-$$

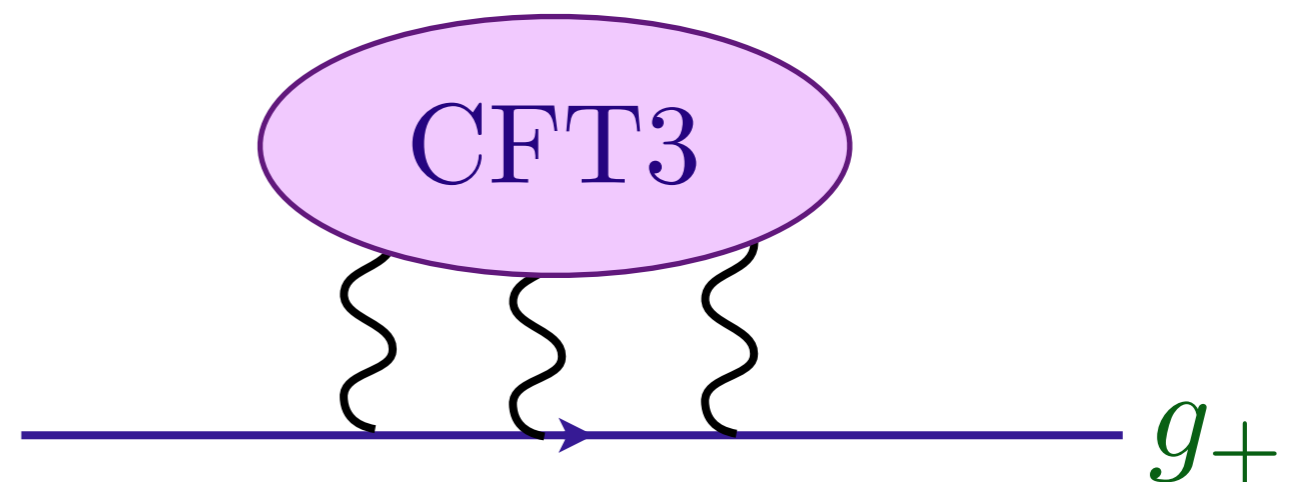
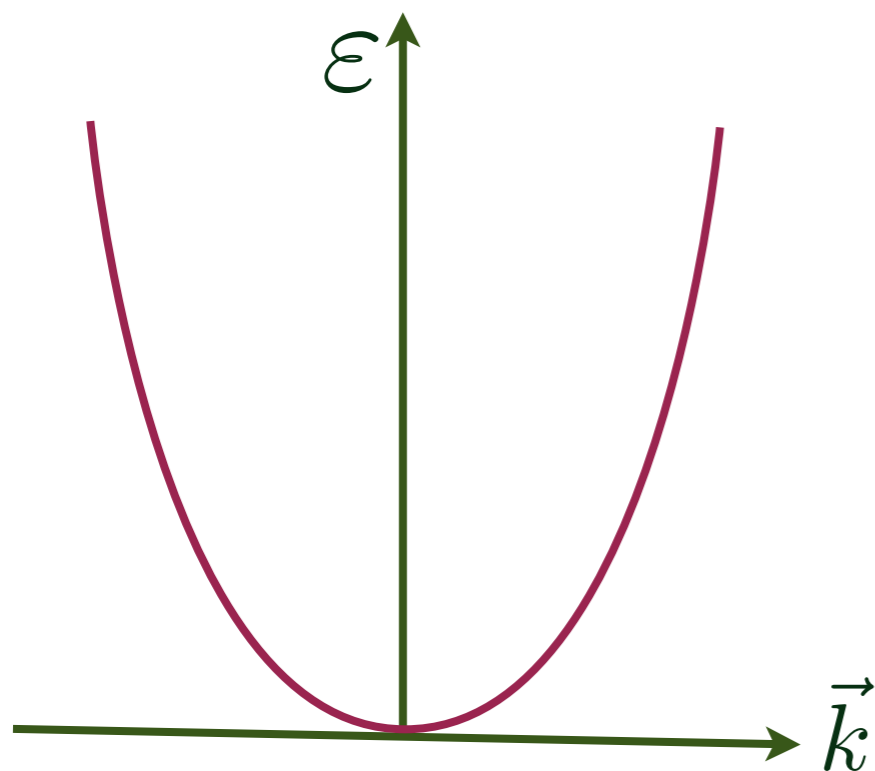

- Begin with a CFT3: the  $CP^1$  model.
- Add “probe” non-relativistic fermions,  $g_+$  and  $g_-$ , with opposite gauge charges
- Turn on fermion chemical potential:

$$\mathcal{L}_f = g_+^\dagger \left( \frac{\partial}{\partial \tau} - iA_\tau - \mu - \frac{1}{2m} \left( \vec{\nabla} - i\vec{A} \right)^2 \right) g_+ + g_-^\dagger \left( \frac{\partial}{\partial \tau} + iA_\tau - \mu - \frac{1}{2m} \left( \vec{\nabla} + i\vec{A} \right)^2 \right) g_-$$

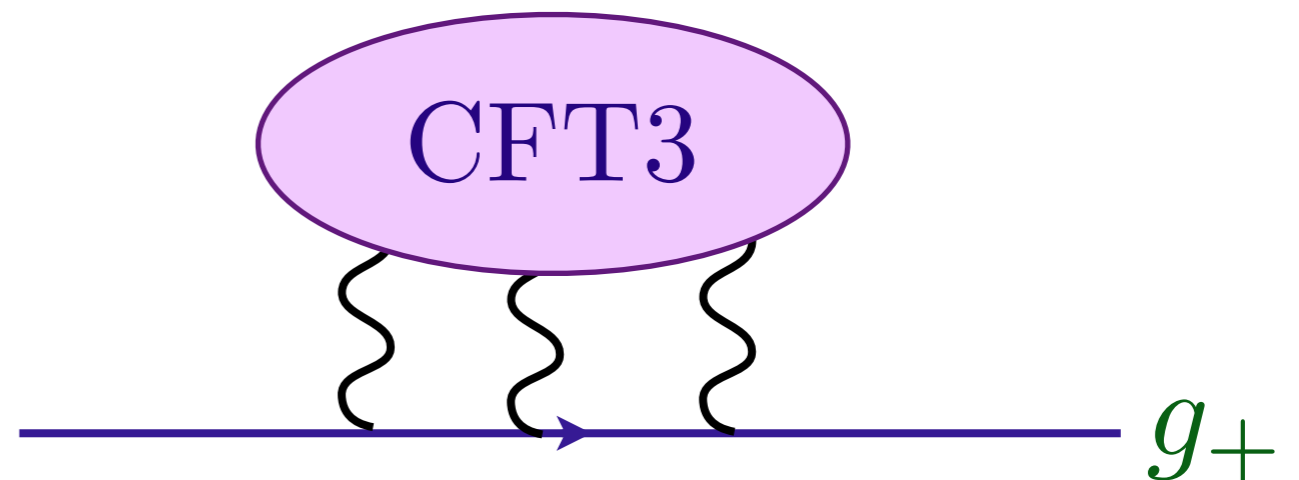
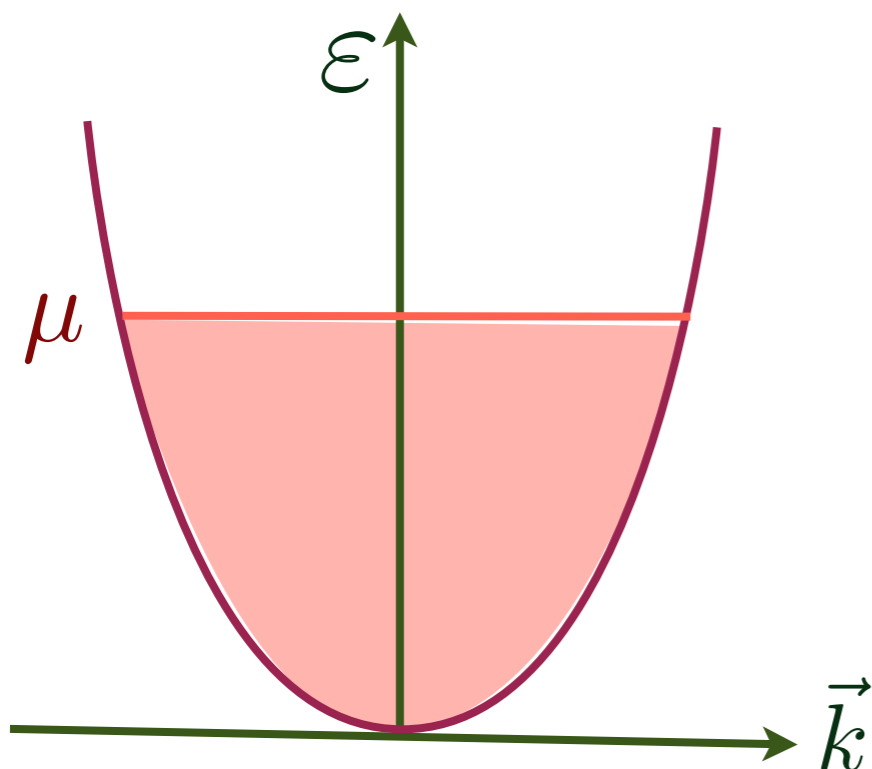

# Complete theory

$$\mathcal{L} = \mathcal{L}_z + \mathcal{L}_f$$

$$\mathcal{L}_z = \frac{1}{\gamma} |(\partial_\mu - iA_\mu)z_\alpha|^2 \quad ; \quad |z_\alpha|^2 = 1$$

$$\begin{aligned} \mathcal{L}_f = & g_+^\dagger \left( \frac{\partial}{\partial \tau} - iA_\tau - \mu - \frac{1}{2m} \left( \vec{\nabla} - i\vec{A} \right)^2 \right) g_+ \\ & + g_-^\dagger \left( \frac{\partial}{\partial \tau} + iA_\tau - \mu - \frac{1}{2m} \left( \vec{\nabla} + i\vec{A} \right)^2 \right) g_- \end{aligned}$$

V. Galitski and S. Sachdev, *Phys. Rev. B* **79**, 134512 (2009).

Theory has *many* similarities to holographic superconductors (Gubser, Hartnoll, Herzog, Horowitz) solved via the AdS/CFT correspondence, which (presumably) describe SYM3 theories in which gluinos pair via exchange of gluons into color singlets, and then Bose condense:

- Fermi surfaces with non-Fermi singularities in spectral functions
- Cooper pairs which are gauge neutral
- Are obtained after doping a CFT3 with finite density of a conserved global charge
- Fermion and current spectral functions in superconducting and normal states have many similarities to cuprates

- Begin with a CFT3: the  $CP^1$  model.
- Add “probe” non-relativistic fermions,  $g_+$  and  $g_-$ , with opposite gauge charges
- Turn on fermion chemical potential:

$$\mathcal{L}_f = g_+^\dagger \left( \frac{\partial}{\partial \tau} - iA_\tau - \mu - \frac{1}{2m} \left( \vec{\nabla} - i\vec{A} \right)^2 \right) g_+ + g_-^\dagger \left( \frac{\partial}{\partial \tau} + iA_\tau - \mu - \frac{1}{2m} \left( \vec{\nabla} + i\vec{A} \right)^2 \right) g_-$$

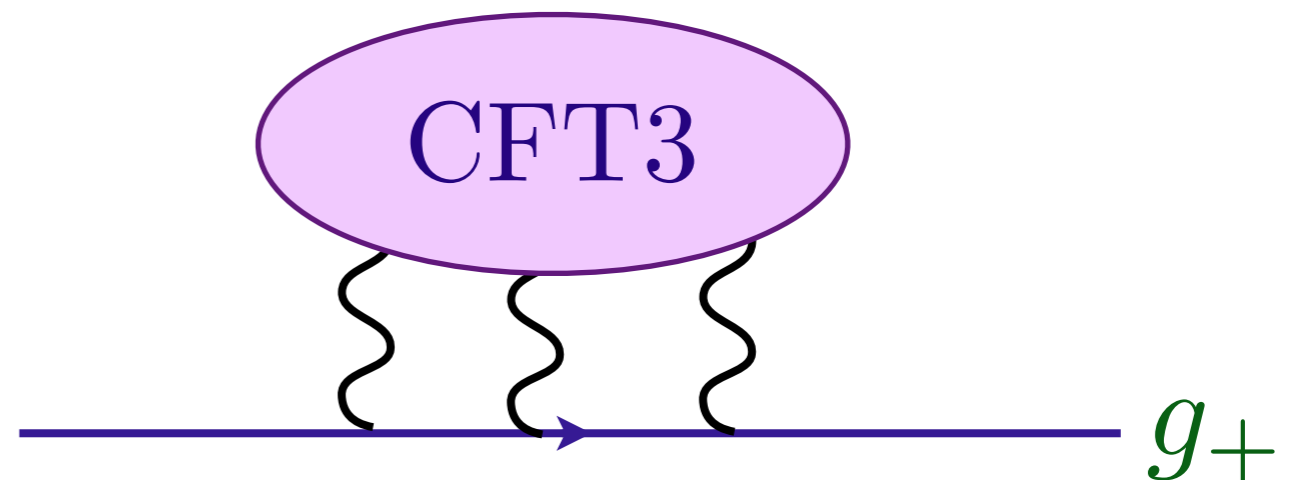
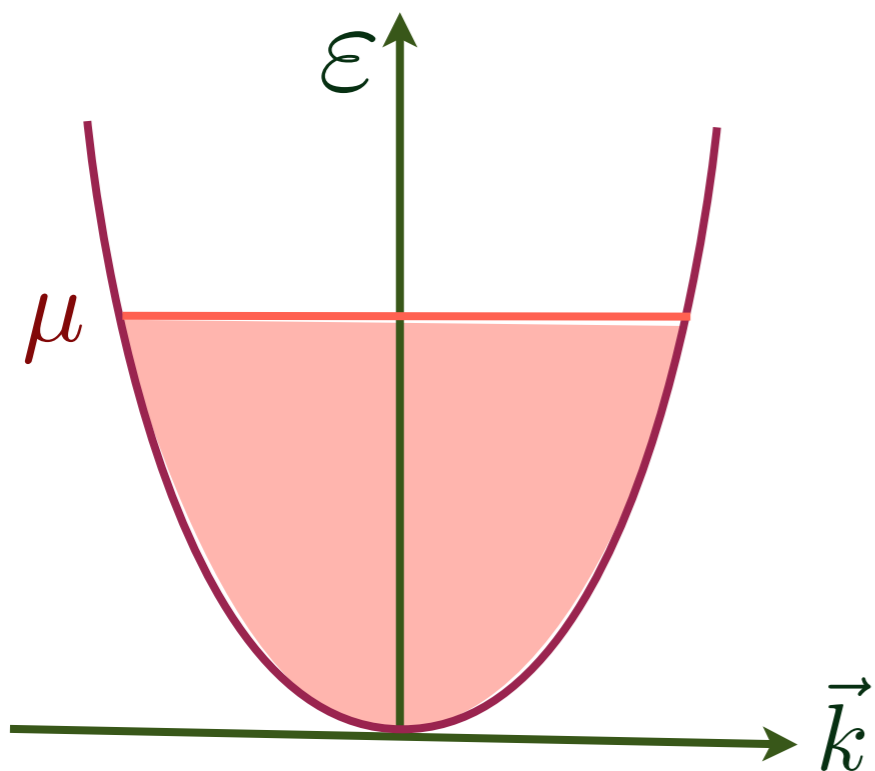

- Begin with a CFT3: the  $CP^1$  model.
- Add “probe” non-relativistic fermions,  $g_+$  and  $g_-$ , with opposite gauge charges
- Turn on fermion chemical potential: leads to a marginal Fermi liquid of  $g_{\pm}$  (not electrons)

$$G(\vec{k}, \omega) = \frac{1}{\omega - v_F(|\vec{k}| - k_F) + c\omega[\ln(|\omega|) + i\pi\text{sgn}(\omega)]}$$

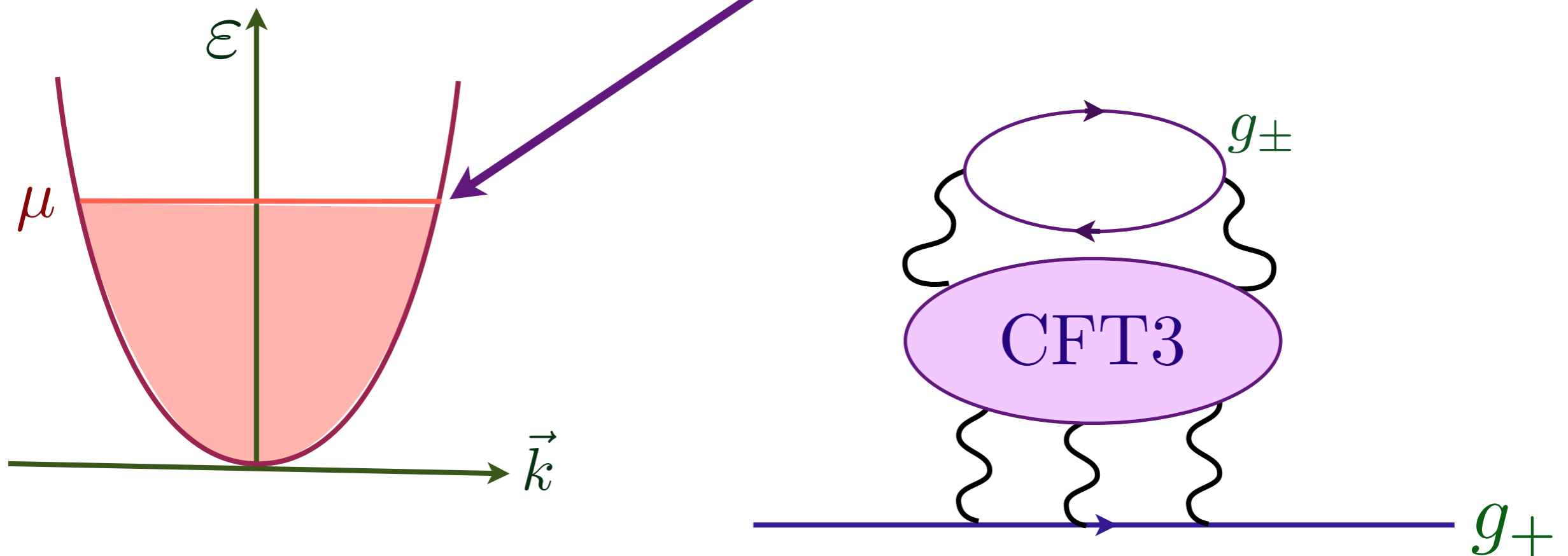

- Begin with a CFT3: the  $CP^1$  model.
- Add “probe” non-relativistic fermions,  $g_+$  and  $g_-$ , with opposite gauge charges
- Turn on fermion chemical potential: leads to a marginal Fermi liquid of  $g_{\pm}$  (not electrons)
- Low  $T$  state is a superconductor with  $\langle g_+ g_- \rangle = \Delta \neq 0$

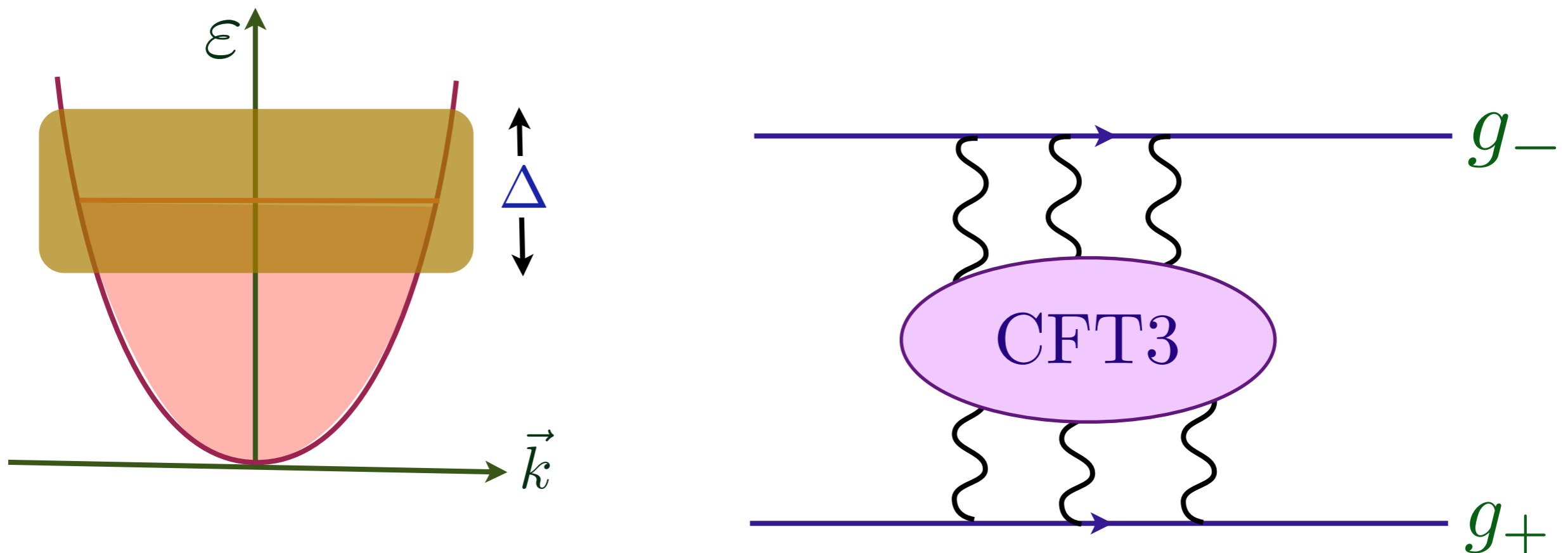

# Why is the pairing $d$ -wave ?

Electron  $c_{2\alpha}$ ,  
spinless fermion  $g_{\pm}$

Electron  $c_{1\alpha}$ ,  
spinless fermion  $g_{\pm}$

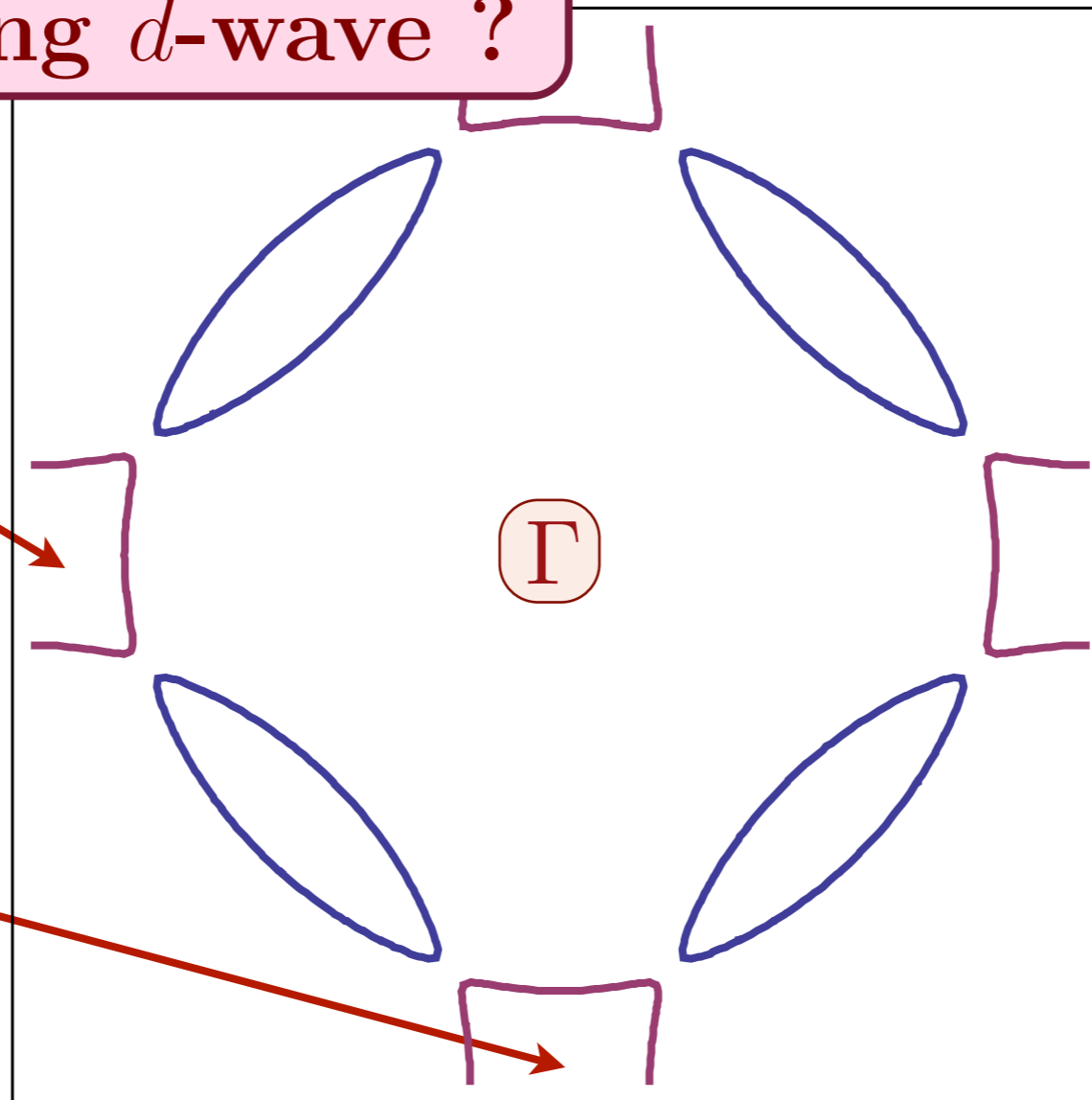

Focus on pairing near  $(\pi, 0)$ ,  $(0, \pi)$ , where  $\psi_{\pm} \equiv g_{\pm}$ ,  
and the electron operators are

$$\begin{pmatrix} c_{1\uparrow} \\ c_{1\downarrow} \end{pmatrix} = \mathcal{R}_z \begin{pmatrix} g_+ \\ g_- \end{pmatrix} ; \quad \begin{pmatrix} c_{2\uparrow} \\ c_{2\downarrow} \end{pmatrix} = \mathcal{R}_z \begin{pmatrix} g_+ \\ -g_- \end{pmatrix}$$

$$\mathcal{R}_z \equiv \begin{pmatrix} z_{\uparrow} & -z_{\downarrow}^* \\ z_{\downarrow} & z_{\uparrow}^* \end{pmatrix}.$$

# Why is the pairing $d$ -wave ?

Electron  $c_{2\alpha}$ ,  
spinless fermion  $g_{\pm}$

Electron  $c_{1\alpha}$ ,  
spinless fermion  $g_{\pm}$

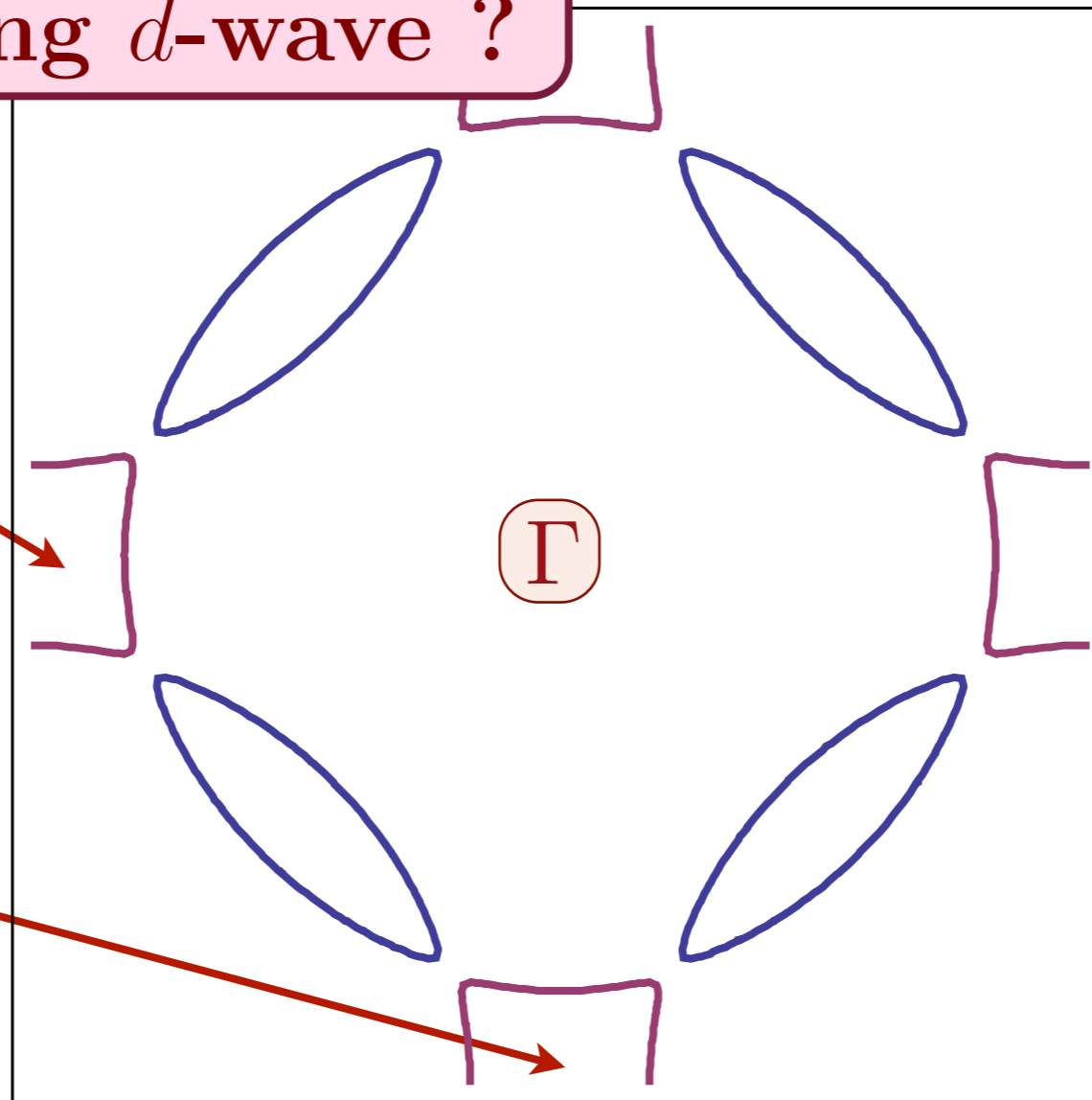

Focus on pairing near  $(\pi, 0)$ ,  $(0, \pi)$ , where  $\psi_{\pm} \equiv g_{\pm}$ ,  
and the electron operators are

$$\begin{pmatrix} c_{1\uparrow} \\ c_{1\downarrow} \end{pmatrix} = \mathcal{R}_z \begin{pmatrix} g_+ \\ g_- \end{pmatrix} ; \quad \begin{pmatrix} c_{2\uparrow} \\ c_{2\downarrow} \end{pmatrix} = \mathcal{R}_z \begin{pmatrix} g_+ \\ \ominus g_- \end{pmatrix}$$

$$\mathcal{R}_z \equiv \begin{pmatrix} z_{\uparrow} & -z_{\downarrow}^* \\ z_{\downarrow} & z_{\uparrow}^* \end{pmatrix}.$$

## Why is the pairing $d$ -wave ?

Fluctuating pocket theory for electrons near  $(0, \pi)$  and  $(\pi, 0)$

Attractive gauge forces lead to simple  $s$ -wave pairing of the  $g_{\pm}$

$$\langle g_+ g_- \rangle = \Delta$$

For the physical electron operators, this pairing implies

$$\begin{aligned}\langle c_{1\uparrow} c_{1\downarrow} \rangle &= \Delta \langle |z_{\alpha}|^2 \rangle \\ \langle c_{2\uparrow} c_{2\downarrow} \rangle &= -\Delta \langle |z_{\alpha}|^2 \rangle\end{aligned}$$

*i.e.*  $d$ -wave pairing !

# T=0 Phase diagram

$$\mathcal{L}_z = \frac{1}{\gamma} |(\partial_\mu - iA_\mu)z_\alpha|^2 \quad ; \quad |z_\alpha|^2 = 1$$

Antiferromagnetic  
order

$$\langle z_\alpha \rangle \neq 0$$

Higgs

Spin liquid/  
Valence bond solid

$$\langle z_\alpha \rangle = 0$$

Coulomb

$\gamma_c$

CFT3

$\gamma$

# T=0 Phase diagram

$$\mathcal{L}_z = \frac{1}{\gamma} |(\partial_\mu - iA_\mu)z_\alpha|^2 \quad ; \quad |z_\alpha|^2 = 1$$

$$\begin{aligned} \mathcal{L}_f = & g_+^\dagger \left( \frac{\partial}{\partial \tau} - iA_\tau - \mu - \frac{1}{2m} \left( \vec{\nabla} - i\vec{A} \right)^2 \right) g_+ \\ & + g_-^\dagger \left( \frac{\partial}{\partial \tau} + iA_\tau - \mu - \frac{1}{2m} \left( \vec{\nabla} + i\vec{A} \right)^2 \right) g_- \end{aligned}$$

## *d*-wave superconductivity

Antiferromagnetic  
order

$$\langle z_\alpha \rangle \neq 0$$

Spin liquid/  
Valence bond solid

$$\langle z_\alpha \rangle = 0$$

$\gamma_c$

CFT3

$\gamma$

# T=0 Phase diagram

$$\mathcal{L}_z = \frac{1}{\gamma} |(\partial_\mu - iA_\mu)z_\alpha|^2 \quad ; \quad |z_\alpha|^2 = 1$$

$$\begin{aligned} \mathcal{L}_f = & g_+^\dagger \left( \frac{\partial}{\partial \tau} - iA_\tau - \mu - \frac{1}{2m} (\vec{\nabla} - i\vec{A})^2 \right) g_+ \\ & + g_-^\dagger \left( \frac{\partial}{\partial \tau} + iA_\tau - \mu - \frac{1}{2m} (\vec{\nabla} + i\vec{A})^2 \right) g_- \end{aligned}$$

## *d*-wave superconductivity

Antiferromagnetic  
order

$$\langle z_\alpha \rangle \neq 0$$

Spin liquid/  
Valence bond solid

$$\langle z_\alpha \rangle = 0$$

$\gamma_c$

CFT3

$\gamma$

# T=0 Phase diagram

Competition between antiferromagnetism and superconductivity shrinks region of antiferromagnetic order: feedback of “probe fermions” on CFT is important

*d*-wave superconductivity

Antiferromagnetic order

$$\langle z_\alpha \rangle \neq 0$$

Spin liquid/  
Valence bond solid

$$\langle z_\alpha \rangle = 0$$

$\gamma_c$

CFT3

$\gamma$

# Theory of quantum criticality in the cuprates

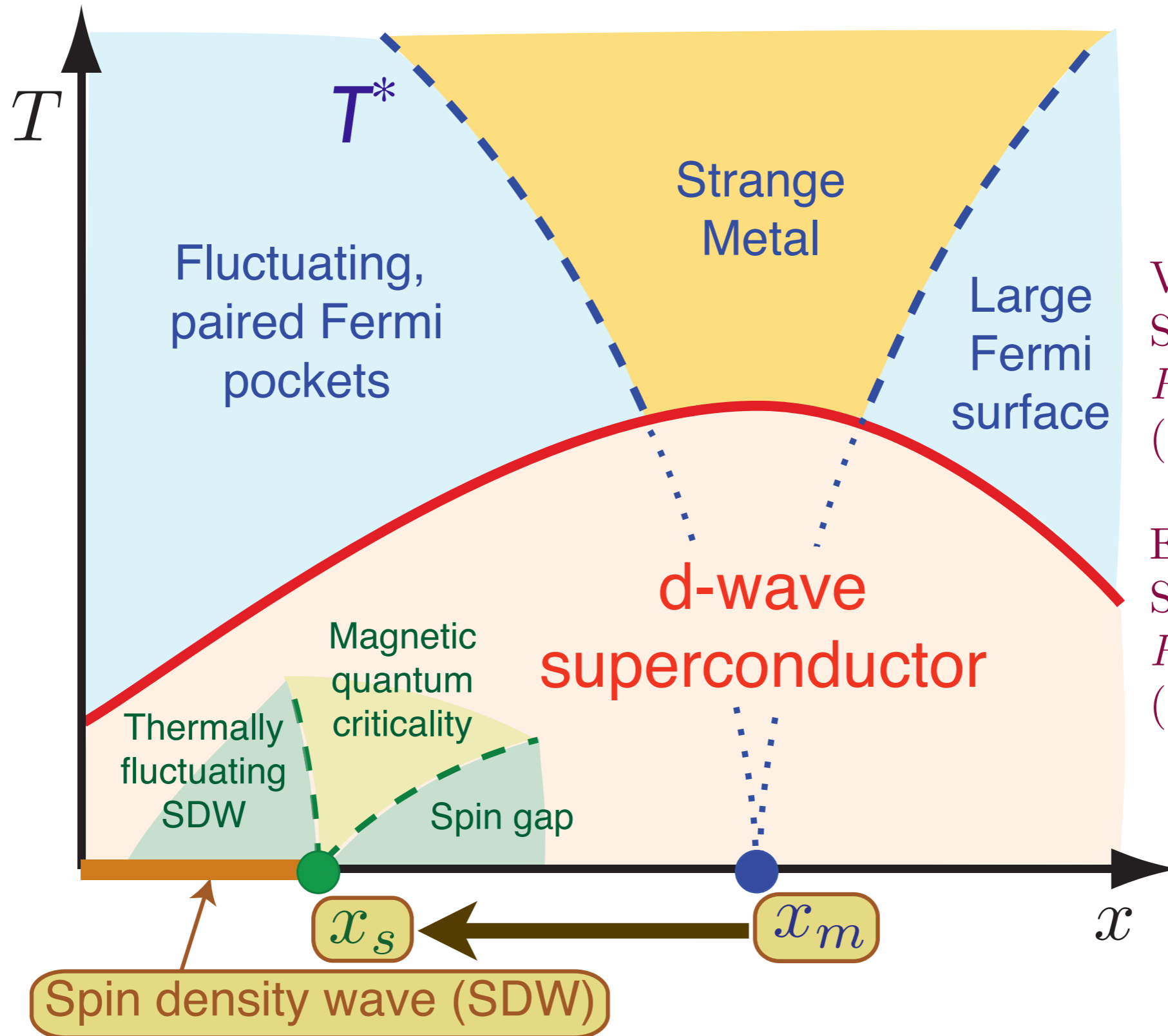

V. Galitski and S. Sachdev, *Phys. Rev. B* **79**, 134512 (2009).

E. G. Moon and S. Sachdev, *Phys. Rev. B* **80**, 035117 (2009)

Competition between SDW order and superconductivity moves the actual quantum critical point to  $x = x_s < x_m$ .

# Theory of quantum criticality in the cuprates

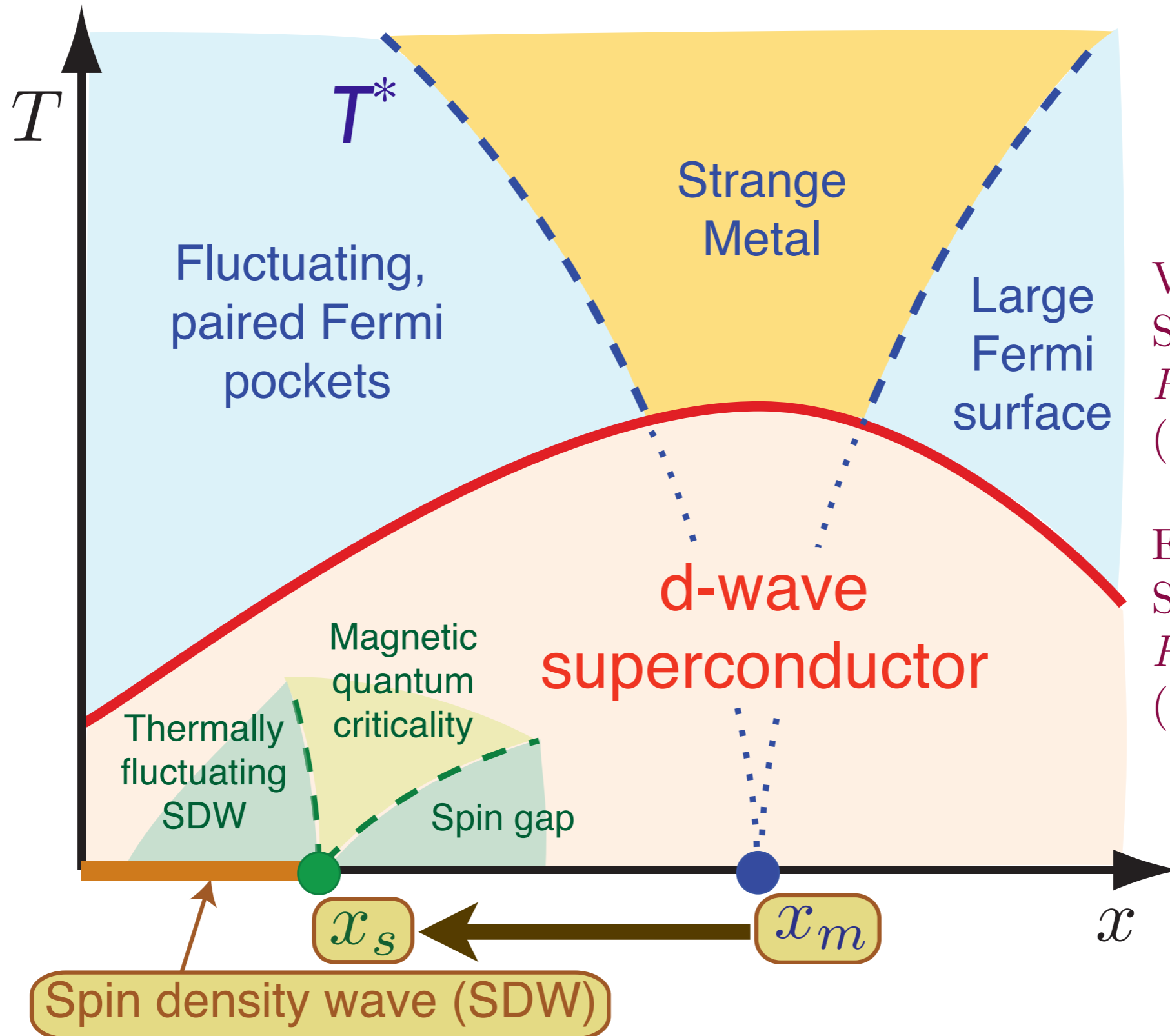

V. Galitski and S. Sachdev, *Phys. Rev. B* **79**, 134512 (2009).

E. G. Moon and S. Sachdev, *Phys. Rev. B* **80**, 035117 (2009)

Physics of competition:  $d$ -wave SC and SDW  
“eat up” same pieces of the large Fermi surface.

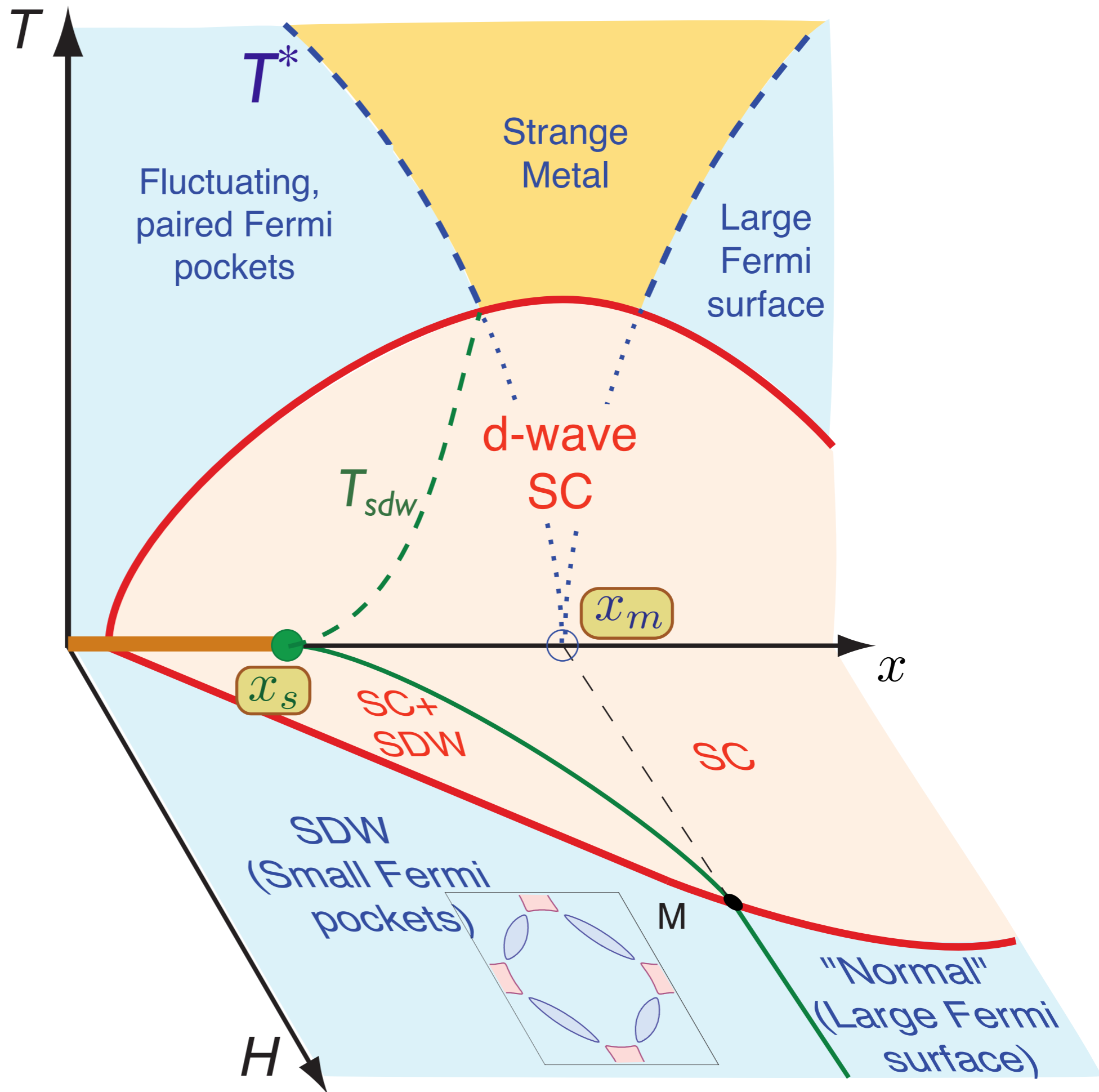

E. Demler, S. Sachdev and Y. Zhang, *Phys. Rev. Lett.* **87**, 067202 (2001).

E. G. Moon and S. Sachdev, *Phy. Rev. B* **80**, 035117 (2009)

# Similar phase diagram for CeRhIn<sub>5</sub>

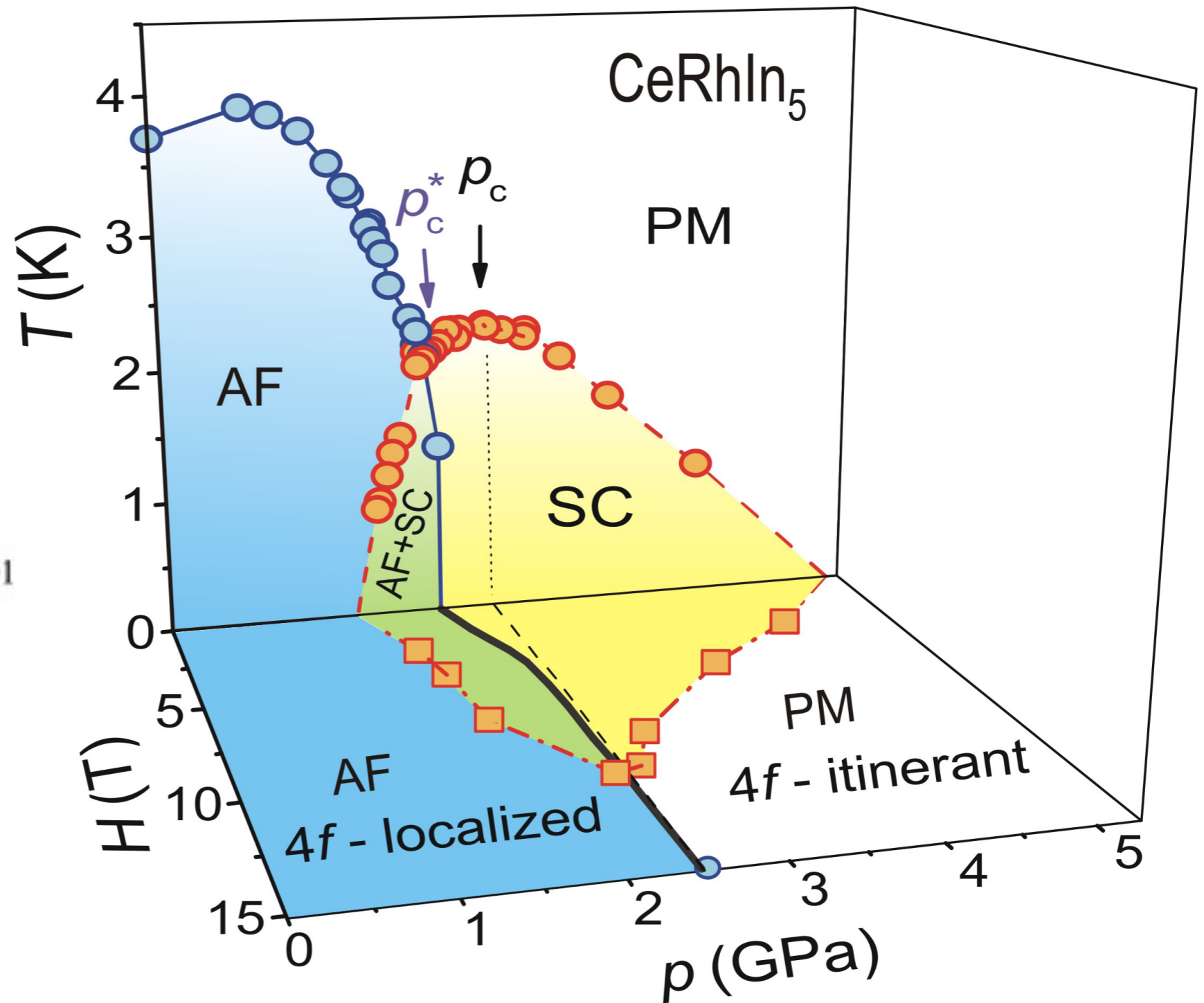
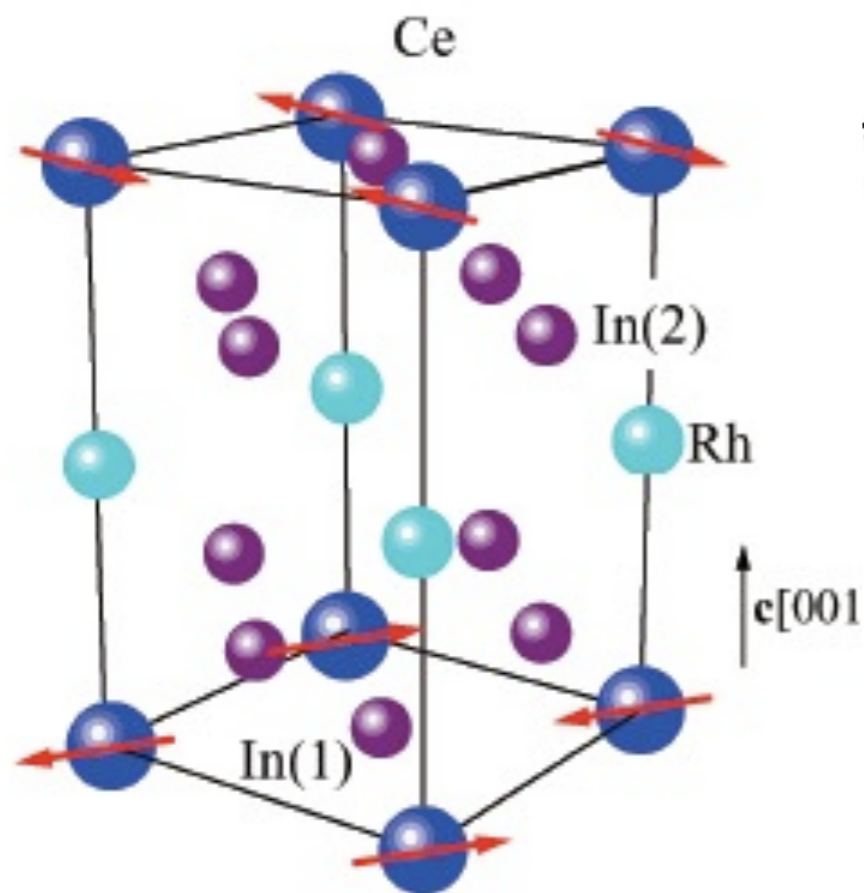

G. Knebel, D. Aoki, and J. Flouquet, arXiv:0911.5223

# Similar phase diagram for the pnictides

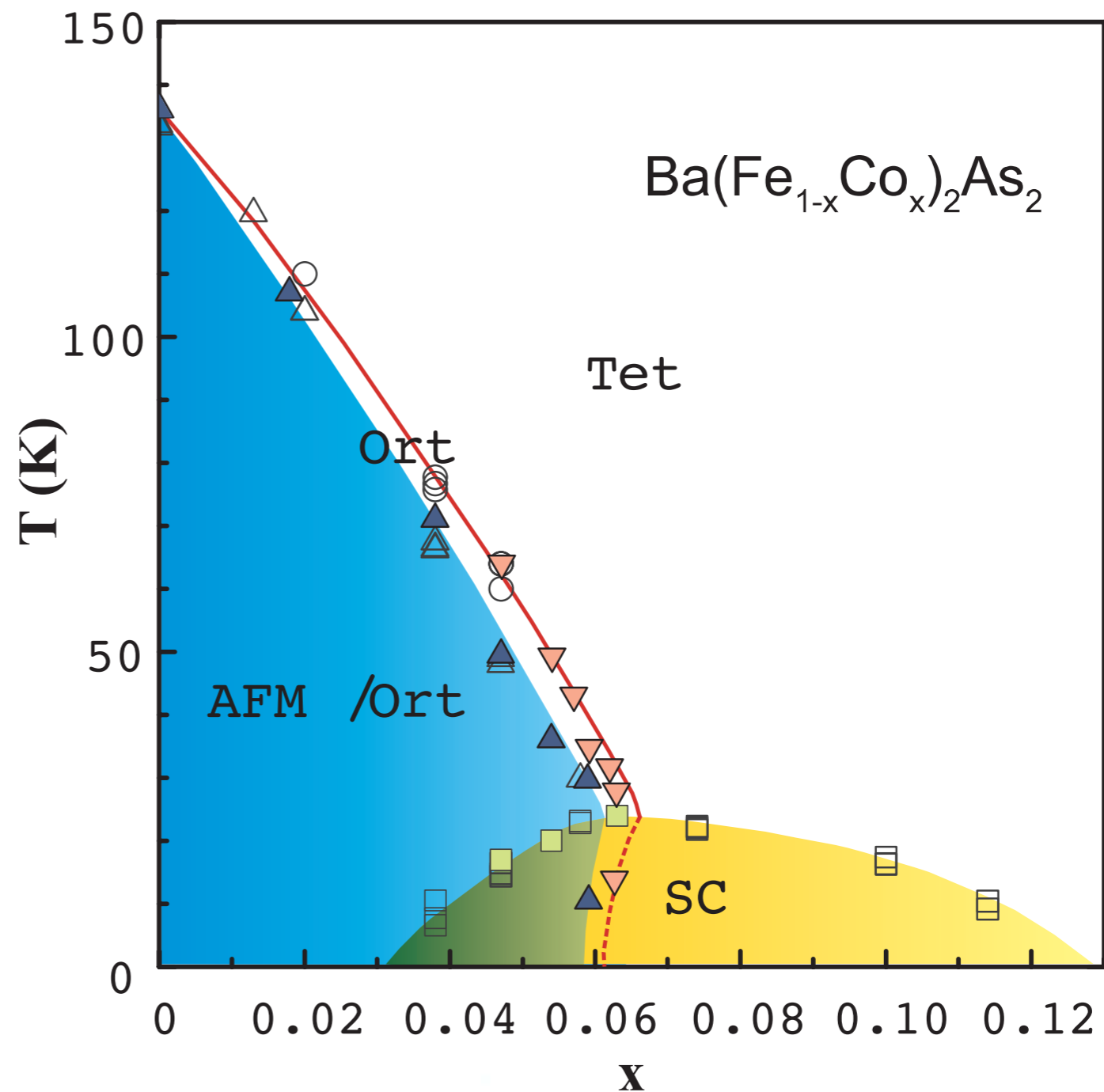
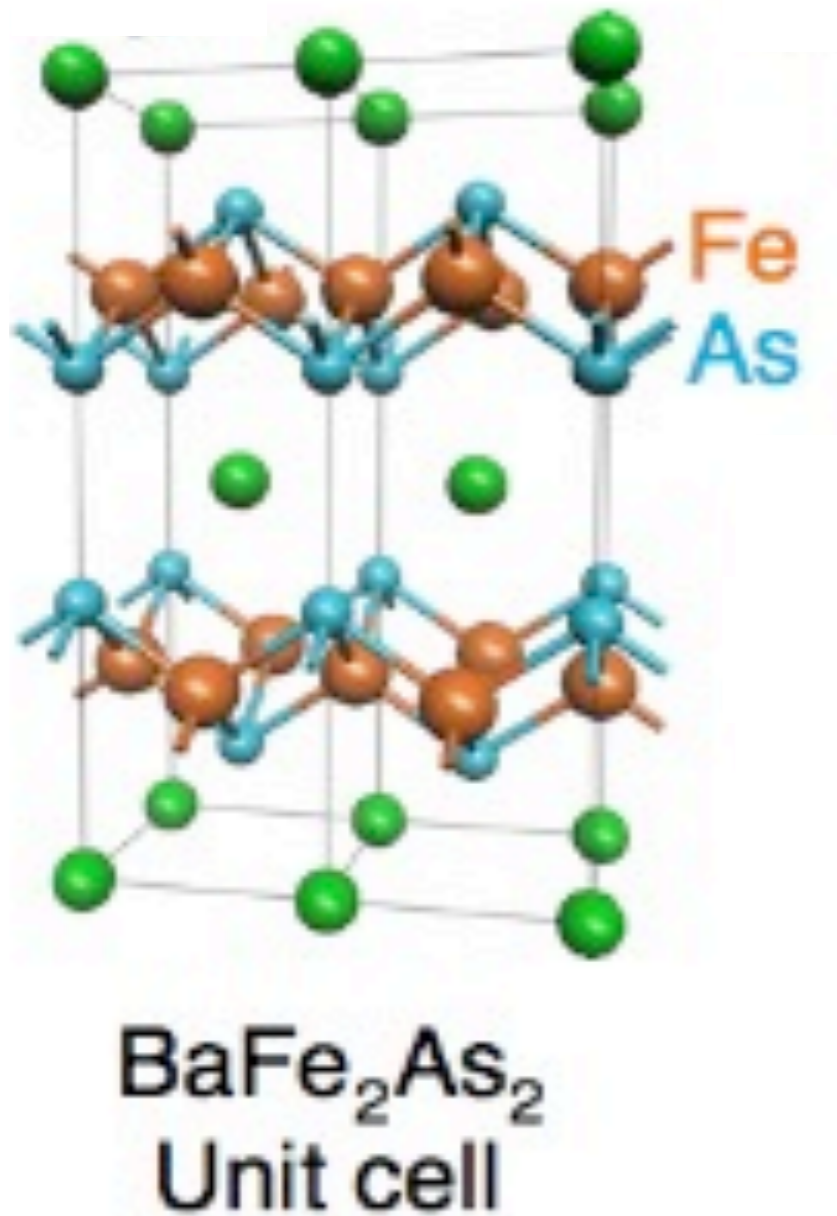

S. Nandi, M. G. Kim, A. Kreyssig, R. M. Fernandes, D. K. Pratt, A. Thaler, N. Ni, S. L. Bud'ko, P. C. Canfield, J. Schmalian, R. J. McQueeney, A. I. Goldman, arXiv:0911.3136.

# Conclusions

General theory of finite temperature dynamics and transport near quantum critical points, with applications to antiferromagnets, graphene, and superconductors

# Conclusions

The AdS/CFT offers promise in providing a new understanding of strongly interacting quantum matter at non-zero density

# Conclusions

Gauge theory for pairing of Fermi pockets in a metal with fluctuating spin density wave order:  
Many qualitative similarities to holographic strange metals and superconductors